



TECHFLEX

Solutions

Braided Sleeving ~~Products~~

• QUALITY • SERVICE • VALUE •



HERITAGE.

Since 1963, the Dermody family founders and operators of TECHFLEX have been engineering and manufacturing a wide range of braided sleeving products for a variety of industries from biomedical and aerospace to wire, hose and cable bundling and protection solutions for hot rod enthusiasts. Our experience with this broad market, as well as our wide selection of general purpose and high-tech specialty products, has made TECHFLEX the first name in braided sleeving solutions.



1948



1969



2000

*3 generations of
customer service &
product expertise*



SERVICE.

We are organized and staffed to provide our customers with the finest products and account support possible. Our account personnel are continuously trained in both technical aspects and application possibilities of our entire line of products.

Through the use of our ISO 9001 certified management system, total product quality is maintained throughout the entire organization, from initial product design through final shipment and account management.

INNOVATION.

It begins with the most varied and complete range of braided sleeving products in the industry and continues with a corporate culture of customer fulfillment and satisfaction. If your application calls for braided sleeving, and the job needs to be done right, Techflex can do it!

Aggressive new product development programs, combined with a management team dedicated to directly targeting the needs of a constantly evolving market, result in a wide range of exciting products that will fully meet your needs for economical and durable sleeving solutions.



Cert. # US04/3598



PRODUCT ACCESS... SIMPLIFIED.

Our catalog reflects our constant dedication to improve customer service. We've made finding products and solutions easier by grouping similar products into application categories. Our advanced product numbering system reflects our commitment to current and future levels of automated management. We've anticipated customer questions and included several pages of step by step instructions for correctly using sleeving and other accessories. New, high quality photography displays the products and applications, in greater detail than ever before, to aid product comparisons and suggest solutions to specific application concerns. We've even expanded and renamed our color codes to make ordering and identification easier and more understandable.



CUSTOMIZATION.

We are completely in-house equipped to fabricate our products into virtually any size or shape, for any application. Services include high speed digital cutting and counting, printing, customized kitting and private labeling programs. We will fabricate custom material and color combinations to tight specifications. We have facilities for multi-step processing such as flattening, rounding, ultrasonic cutting and welding. Our custom services can help you realize your design and application goals.



In-house clean room for medical grade processing & testing.



PRODUCT CONTROL.

Techflex sets the industry standard for the continuous tracking of products, from their earliest manufacturing steps through final delivery to customers at any volume level. Managed receiving of inventory, automatic lot and spool tracing, originator documentation, and constant quality testing and documentation ensure that included products will perform as indicated and will meet the specific needs of all of our customers.

These systems, along with our program of product reliability assurance means that our customers can remain confident that any Techflex product will not only meet industry standards, but may vastly exceed them in many instances.



Underwriter's Laboratories



Canadian Standards Association



Restriction of Hazardous Substances Directive



Recyclable
www.techflex.com/recycle

MSHA
Mine Safety And Health Administration

ABYC
Setting Standards For Safer Boating
American Boat And Yacht Council

FMVSS
Federal Motor Vehicle Safety Standard

FAR-25
Federal Aviation Regulation 25

7 Reasons to Use FLEXO Expandable Sleeving

- **Fast Installation**

Unlike other techniques for cable management, expandable sleeving goes on fast and is able to go over connectors up to 3 times the size of the finished harness.

- **Long Length Capability**

The unique characteristics of FLEXO expandable sleeving allow it to easily slide over cable installations as long as 1,000'. No pulling or fishing required.

- **Extreme Flexibility**

Unlike stiff plastic coverings, harnesses built with expandable sleeving can be tightly coiled, curved around obstructions and routed to their destination more easily. FLEXO sleeving easily conforms to your desired shape.

- **Reduced Volume**

FLEXO sleeving provides needed abrasion protection without adding unnecessary bulk or dimension to harnesses and cables. This helps in routing wiring through tight spaces.

- **Light Weight**

Expandable sleeving is very light when compared to other harness materials. This weight reduction can add up to considerable savings when used on large and small projects.

- **Quick Dissipation of Moisture**

This feature of expandable sleeving is useful in rugged applications where soaking and wash downs are common. Unlike sealed tubular products, FLEXO sleeving doesn't trap moisture, grease or oils which can harm wire jacketing.

- **Unbeatable Great Looks**

We're convinced that no product looks as good on a harness as FLEXO expandable sleeving. This, combined with all of the other factors, add up to an easy conclusion...

FLEXO is the right choice.

Products

General Purpose Products

For general bundling and protection in office, commercial and industrial applications. These products offer economical and varied solutions.

Heavy Duty Products

In applications where protection from abrasion damage is a primary concern, this line of Techflex products is the right solution for rugged, challenging environments.

Metal/Shielding Products

Techflex provides many EMI, RFI & ESD shielding solutions appropriate for a wide variety of applications.

Advanced Engineering Products

Engineered from specialized polymers, designed to exacting specifications and manufactured to tight tolerances, these premium products are in use in many aerospace, military and biomedical applications.

Extreme Temperature Products

Designed for protection from high temperature environments where failure would be catastrophic, these products are the state-of-the-art in high temp material engineering.

Specialty Products

Techflex specializes in providing highly engineered, application specific products to fulfill our customer's individual specifications.



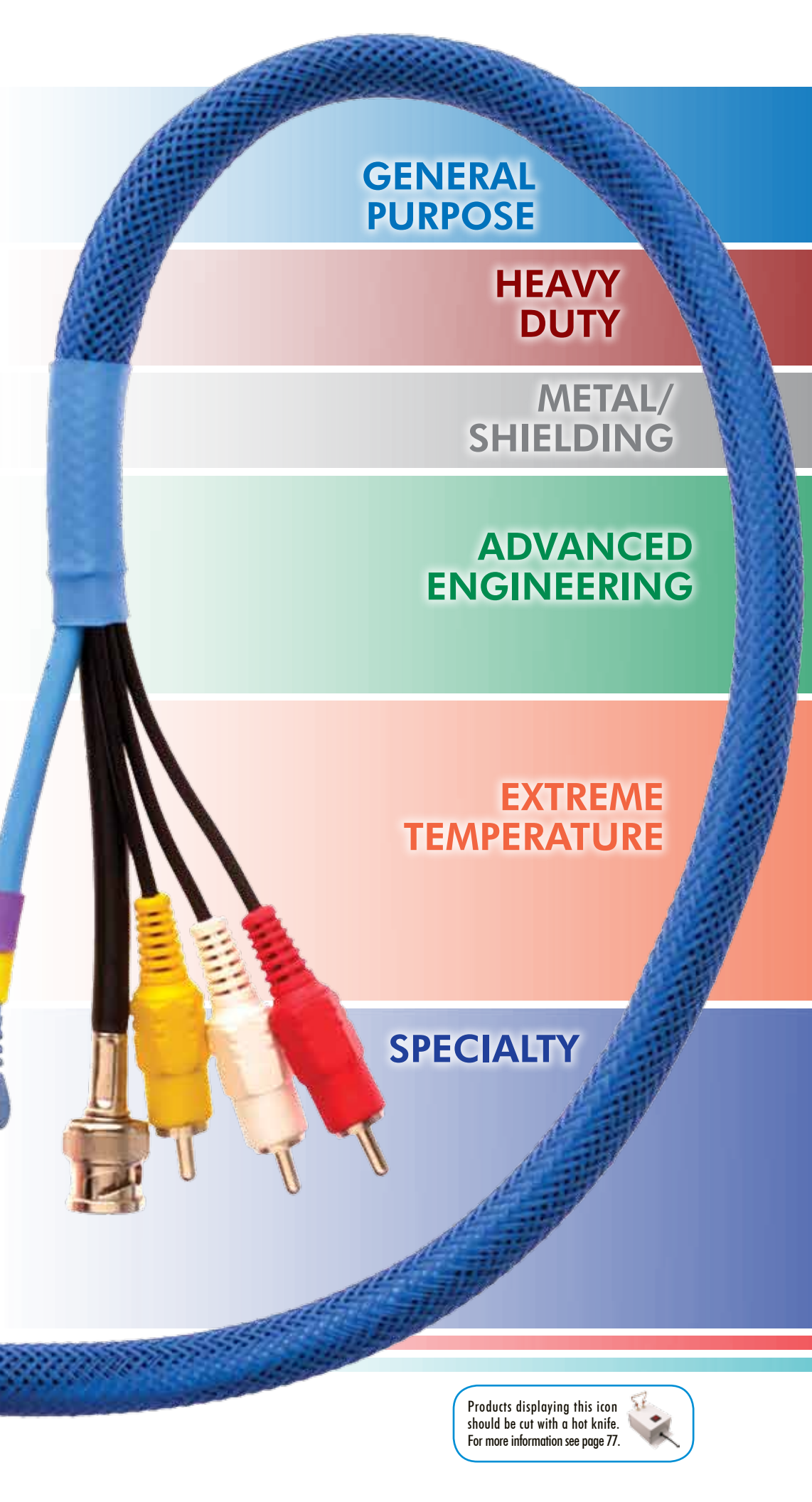

**GENERAL
PURPOSE**

**HEAVY
DUTY**

**METAL/
SHIELDING**

**ADVANCED
ENGINEERING**

**EXTREME
TEMPERATURE**

SPECIALTY

PRODUCTS

Flexo PET.....	4-6
ReMix.....	5
Overexpanded.....	6
Tight Weave.....	6
Clean Cut.....	7
F6.....	8-9
Flexo Wrap.....	10
Grip Wrap.....	11
Heavy Wall.....	12
Flexo Super Duty.....	13
Gorilla.....	14
Dura-Wrap.....	15
Dura-Flex.....	16
Dura-Flex Pro.....	17
Metal Braid.....	18
Stainless Steel.....	19
Stainless Steel XC.....	19
Flexo Shield.....	20
Flexo Conductive.....	21
Clean Cut FR.....	22
Flexo FR.....	23
Liquid Wrap.....	24
F6 FR.....	25
Flexo Wrap FR.....	26
Tight Weave FR.....	27
Flexo Halar.....	28
Teflon.....	29
Flexo PPS.....	30
Kevlar.....	31
Vectran.....	31
PEEK.....	32
Insultherm.....	33
Insultherm Tru-Fit.....	34
Insultherm Ultraflexx.....	35
Insultherm Ultraflexx Pro.....	35
Insultherm Sleeves.....	36
Header Wrap.....	37
Header Wrap SI.....	37
Volcano Wrap.....	38
Silica Sleeve.....	39
ThermaShield T6.....	40
ThermaShield.....	41-42
Nomex.....	43
Weld-Wrap.....	44
FireFlex.....	45
FireFlex Aero.....	46
Studio Key Sleeve.....	47
Flexo Mounting System.....	48
Dura-Race.....	49
Non-Skid.....	50
Nylon Monofilament.....	51
Nylon Multifilament.....	52
Mylar.....	53
Chrome & Chrome XC.....	54
Flexo 6 Mil.....	55
Flexo Thin.....	55
Carbon Fiber.....	56
Reflex.....	57
F6 Reflex.....	57
Flexo Noise Reduction.....	58
F6 Quiet.....	58
Part Guard.....	59
Electrical Insulation.....	60-63
Heatshrink Tubing.....	64-71
Terminations & Bundling.....	72-74
Tools & Accessories.....	75-78
Custom Services.....	79-80
Product Comparison.....	81-85

Products displaying this icon should be cut with a hot knife. For more information see page 77.





Flexo PET

- Economical and Easy to Install
- Cut and Abrasion Resistant
- Expands up to 150%
- Halogen Free
- Resists Gasoline, Engine Chemicals and Cleaning Solvents
- FMVSS 302 Approved

A Versatile Bundling & Protection Solution

The FLEXO PET (PT) grade is used in electronics, automotive, marine and industrial wire harnessing applications where cost efficiency and durability are critical. The unique braided construction and wide expandability allows quick and easy installation over large connectors and long runs. PT can be found in applications ranging from small office/home office to high tech wire and cable harnesses. The wide range of available colors and sizes allows easy and systematic color coding in complex wiring and cabling installations. PT is braided from 10 mil polyethylene terephthalate (PET) monofilament yarns. The material has a wide operating temperature range, is resistant to chemical degradation, UV radiation, and abrasion. The sleeving cuts easily and cleanly with a hot knife and once installed, will beautify and protect any wire, hose or cable application.

The Widest Range of Sizes in The Industry



When cut with a hot knife, the sealed ends of PET allow for varied termination solutions.



Flexo PET installs quickly in production harnessing environments, reducing assembly cost.



High thermal and chemical resistance and wide color/size selection make PET ideal for customizing and protecting the wires, hoses and cables in custom and classic cars.



Nominal Size	Part #	Expansion Range		Standard Spool Put-Ups		Available Colors	Lbs/ 100'
		Min.	Max.	Bulk Spool	Shop Spool		
1/8"	PTN0.13	3/32"	1/4"	1,000'	225'	27 colors	0.18
1/4"	PTN0.25	1/8"	7/16"	1,000'	200'	27 colors	0.26
3/8"	PTN0.38	3/16"	1/2"	500'	125'	27 colors	0.57
1/2"	PTN0.50	1/4"	3/4"	500'	100'	27 colors	0.77
5/8"	PTN0.63	3/8"	1"	500'	100'	27 colors	0.95
3/4"	PTN0.75	1/2"	1 1/4"	250'	75'	27 colors	1.20
1"	PTN1.00	5/8"	1 5/8"	250'	65'	27 colors	1.34
1 1/4"	PTN1.25	3/4"	1 3/4"	250'	50'	27 colors	1.60
1 1/2"	PTN1.50	1"	2 1/8"	200'	40'	27 colors	1.96
1 3/4"	PTN1.75	1 1/4"	2 3/4"	200'	30'	27 colors	2.45
2"	PTN2.00	1 1/2"	3 1/2"	200'	50'	27 colors	3.30
2 1/2"	PTN2.50	1 3/4"	3 5/8"	200'	50'	27 colors	3.80
3"	PTN3.00	2 1/2"	4 3/4"	100'	50'	27 colors	4.00
3 End Construction							
1/4"	PT30.25	1/8"	3/8"	1,000'	200'	BK, CL & NB	0.39
9 Mil Construction							
4"	PT94.00BK	4"	6 1/2"	100'	50'	Black (BK)	3.80
PET Lean							
3/4"	PTL0.75BK	1/2"	1 1/4"	250'	75'	Black (BK)	1.04
1 1/4"	PTL1.25BK	3/4"	1 3/4"	250'	50'	Black (BK)	1.19





Flexo PET

The Widest Range of Colors in The Industry

Techflex offers Flexo PET in the widest range of standard colors in the industry, including UV reactive and multi-color spirals. Additionally, we can manufacture Flexo PET in custom solid or spiral combinations. Contact an Account Representative for relevant details regarding custom orders.



*UV Reactive



Flexo PET-M

FLEXO PET REMIX - New, Random Construction

Our innovative construction process produces a unique visual effect while providing fuller coverage and enhanced protection. The same PET monofilaments we use for the FLEXO PET grade sleeving come alive in these new color combinations. Use Denim, Fire, Camo & Desert Camo to add pizzazz to any place you use sleeving.

Nominal Size	Part #	Expansion Range		Standard Spool Put-Ups		Available Colors	Lbs/100'
		Min.	Max.	Bulk Spool	Shop Spool		
3/8"	PTM0.38	1/4"	7/16"	500'	125'	DE, FI, CA & DC	0.49
1/2"	PTM0.50	3/8"	5/8"	500'	100'	DE, FI, CA & DC	0.74
3/4"	PTM0.75	5/8"	1 3/16"	250'	75'	DE, FI, CA & DC	0.99
1 1/4"	PTM1.25	1 1/8"	1 3/4"	250'	65'	DE, FI, CA & DC	1.32
1 1/2"	PTM1.50	1 3/8"	2 3/8"	200'	40'	DE, FI, CA & DC	1.65



Flexo PET-O

- Expands up to 200%
- Cut and Abrasion Resistant
- Halogen Free
- FMVSS 302 Approval

Extra Expansion for Easy Application

FLEXO PET OVEREXPANDED (PT) has many uses where inexpensive bundling is the principal consideration. Created to provide a fast easy bundling solution for automotive and marine wiring. Overexpanded opens nearly 4 to 1 making it very easy to apply. The open construction allows the underlying harness or covering to show through for a unique and attractive assembly. The material cuts easily with either scissors or a hot knife.



Nominal Size	Part #	Expansion Range		Standard Spool Put-Ups		Available Colors	Lbs/100'
		Min.	Max.	Bulk Spool	Shop Spool		
1/4"	PTO0.25	1/8"	1/2"	1,000'	200'	BK	0.24
3/8"	PTO0.38	3/16"	1"	500'	125'	BK,CL,PP,NB,RD,NY,CB	0.52
1/2"	PTO0.50	7/16"	1 3/8"	500'	100'	CL & BK	0.63

Flexo PET-T

- Complete Coverage
- Improved Abrasion Resistance

Tight Weave for Extra Coverage

TIGHT WEAVE (PT) is designed for use in applications where optimum coverage and abrasion resistance is required. The tight braid construction increases the coverage, wear factor and improves harness security.



Nominal Size	Part #	Expansion Range		Standard Spool Put-Ups		Available Colors	Lbs/100'
		Min.	Max.	Bulk Spool	Shop Spool		
1/4"	PTT0.25BK	11/64"	11/32"	1,000'	200'	Black (BK)	0.36
5/16"	PTT0.31BK	23/64"	19/32"	1,000'	200'	Black (BK)	0.58
1/2"	PTT0.50BK	11/32"	5/8"	500'	100'	Black (BK)	0.84
3/4"	PTT0.75BK	1/2"	13/16"	250'	75'	Black (BK)	1.10
1"	PTT1.00BK	5/8"	1 1/8"	250'	65'	Black (BK)	1.23
1 1/4"	PTT1.25BK	1"	1 11/16"	250'	50'	Black (BK)	1.30
1 1/2"	PTT1.50BK	1 1/8"	2"	200'	40'	Black (BK)	1.95
1 3/4"	PTT1.75BK	1 1/2"	2 5/8"	200'	30'	Black (BK)	2.60
2"	PTT2.00BK	1 3/4"	3 1/8"	200'	50'	Black (BK)	3.43

Also available in FR. Go to page 27.





Clean Cut

Scissor Cut for Easy, Fray Resistant Installation in Production or Field

By adjusting the physical characteristics of the polyethylene terephthalate filaments, the engineers at Techflex have produced a product with the same specifications as our PET with the unique advantage of being able to cut the material with ordinary scissors and still maintain an extraordinarily fray-resistant end.

FLEXO CLEAN CUT (CC) is ideal for field installers and other situations where access to a hot knife is impossible. CC's fray-resistant properties allows frequent expansion at the cut end without unraveling. When cut with a hot knife, CC produces a virtually frayless end.

Clean Cut sets the highest standard for uncoated fray resistance sleeving products.

- **Resists Fraying when Cut with Scissors**
- **Increased Braid Density for Fuller Coverage**
- **High Abrasion Resistance**
- **Temperature Range -94°F to 257°F**
- **Melt Temp. 482°F**



Clean Cut cuts easily and neatly with regular scissors and maintains a fray resistant end during installation.



When scissor cut, the end of Clean Cut will withstand heavier handling without fraying than standard PT.

Nominal Size	Part #	Expansion Range		Standard Spool Put-Ups		Available Colors	Lbs/100'
		Min.	Max.	Bulk Spool	Shop Spool		
1/8"	CCP0.13	1/8"	1/4"	1,000'	100'	BK & GY	0.40
1/4"	CCP0.25	5/32"	7/16"	1,000'	100'	BK & GY	0.46
3/8"	CCP0.38	3/16"	5/8"	500'	100'	BK & GY	0.74
1/2"	CCP0.50	1/4"	3/4"	500'	100'	BK & GY	0.82
3/4"	CCP0.75	5/8"	1"	250'	75'	BK & GY	1.11
1"	CCP1.00	3/4"	1 3/16"	250'	50'	BK & GY	1.24
1 1/4"	CCP1.25	1"	1 1/2"	250'	50'	BK & GY	1.56
1 1/2"	CCP1.50	1 1/4"	2"	250'	50'	BK & GY	1.85





Flexo F6

- **Easy, Cost Effective Installation**
- **More Flexible than Split Convuluted or Spiral Wrap**
- **25% Edge Overlap**
- **Cut and Abrasion Resistant**
- **Halogen Free**
- **Retains Shape & Rigidity Throughout -94°F to 257°F Temp. Range**
- **Melt Temp 482°F**

Flexible, Semi-Rigid Wrappable Split Braided Tube

FLEXO F6's unique split, semi-rigid braided construction makes it the ideal solution for situations where ease of installation is of primary importance. The lateral split allows the tube to open up to accommodate a wide variety of bundling requirements, and the semi-rigid braid configuration simply closes around the entire installation without the need for any additional fasteners (Velcro, tape, etc.). The 10 mil PET braid is lightweight, quiet and flexible. The 25% edge overlap (at nominal diameter) allows coverage around inline plugs, connectors and splices.

F6 will bend to a tight radius without distorting or splitting open and, unlike full rigid tubing, will not impair or affect the flexibility of harnesses. Allows for addition or removal of wires without disassembly.



F6 is available in self storing boxes.

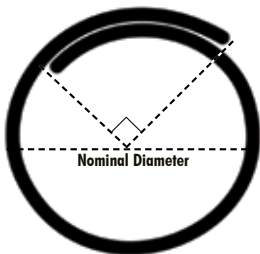

The large overlap allows easy installation over splices and inline connectors without exposing wires and cables.



F6 orange is used for safety identification in both electric powered vehicles and military aircraft.



Nominal Size	Part #	Wall Thickness	Standard Put-Ups			Available Colors	Lbs/100'
			Bulk Box	Box A	Box B		
1/8"	F6N0.13	.024"	10,000'	400'	100'	BK, OR, PG, CW	0.20
1/4"	F6N0.25	.025"	3,000'	200'	100'	BK, OR, PG, CW	0.60
3/8"	F6N0.38	.025"	1,000'	150'	75'	BK, OR, PG, CW	1.20
1/2"	F6N0.50	.025"	1,200'	150'	75'	BK, OR, PG, CW	1.40
3/4"	F6N0.75	.025"	500'	100'	50'	BK, OR, PG, CW	1.60
1"	F6N1.00	.038"	400'	100'	50'	BK, OR, PG, CW	2.00
1 1/4"	F6N1.25	.038"	250'	75'	25'	BK, OR, PG, CW	2.40
1 1/2"	F6N1.50	.038"	200'	75'	25'	BK, OR, PG, CW	2.70
2"	F6N2.00	.038"	150'	50'	25'	BK, OR, PG, CW	3.60

800 323-5140
www.techflex.com





Flexo F6



F6 Installation Tool
This simple tool makes installing long lengths of F6 sleeving a breeze. Just insert your bundle of wires into the shank of the tool and slide it along the split in the sleeving. As the tool travels along the sleeving, it deposits the wires and allows the split to close correctly. See part numbers on page 73.



Flexo Wrap

- **Heavy Duty Hook and Loop Closure for Frequent Access**
- **Expands to Fit Over Inline Connectors and Splices**
- **Halogen Free**
- **Temperature Range -94°F to 257°F**
- **Melt Temp. 482°F**

Flexible Control & Management with Easy On, Easy Off Access

FLEXO WRAP (FW) is an exclusive product engineered and manufactured by Techflex. FW provides the perfect solution to a wide variety of unique application challenges.

The color matched hook and loop closure provides for easy on and off installation, as well as instant and convenient access for harness break-outs and rework of any specific section along the entire length of the run. Combined with the expandable, open weave design, FW will conform to a wide variety of bundle diameters and will wrap around irregular shapes.

All grades of FW cut cleanly with a hot knife.

FLEXO WRAP is designed for quick and easy management of wire, cable and hose assemblies. Just separate the hook and loop fasteners along the edge of the material....



and slip the entire length of FW around or under your harness or component assembly. The wide expandability range allows FW to easily fit around...



odd-shaped connectors and gently constrict around the diameter of your wires. When the FW is in place, simply seal the hook and loop along the edges.



Nominal Size	Part #	Hook & Loop Width	Standard Spool Put-Ups		Available Colors	Lbs/100'
			Bulk Spool	Shop Spool		
1/2"	FWN0.50	1/4"	100'	20'	BK, WH, GY & BE	1.30
3/4"	FWN0.75	5/8"	100'	15'	BK, WH, GY & BE	1.80
1 1/4"	FWN1.25	5/8"	100'	12'	BK, WH, GY & BE	2.30
2"	FWN2.00	5/8"	100'	10'	BK, WH, GY & BE	3.20
2 1/2"	FXN2.50BK	5/8"	100'	10'	BK	3.75



Grip Wrap

Adjustable Diameter Sleeve with Easy On, Easy Off Access

GRIP WRAP (GW) is a lightweight, abrasion resistant sleeving with a unique hook sealing system that eliminates spot taping and does not require an open end for installation. The sleeving permits easy access for inspection, rework or replacement of components.

Grip Wrap provides cut-through and abrasion protection, and is easily applied to areas restricted by breakouts and large end fittings. Can be used to bundle wire harnesses, and also can be used to substitute molded channels.

The unique Grip Wrap system provides a variety of sealing and mounting options to accommodate any harnessing or cable management application.

One Size - Multiple Possibilities

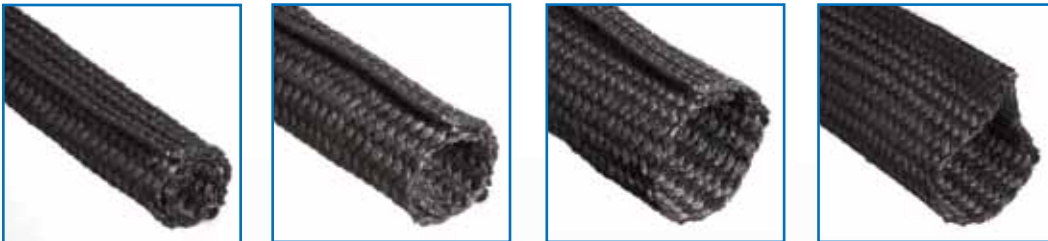

- **Wrappable Design for Easy Installation and Removal**
- **Excellent Protection Against Cut-Through, Abrasion and Impact**
- **Closure Maintains Low Profile For Flat Cables & Harnesses**
- **Temperature Range -94°F to 257°F**
- **Melt Temp. 482°F**

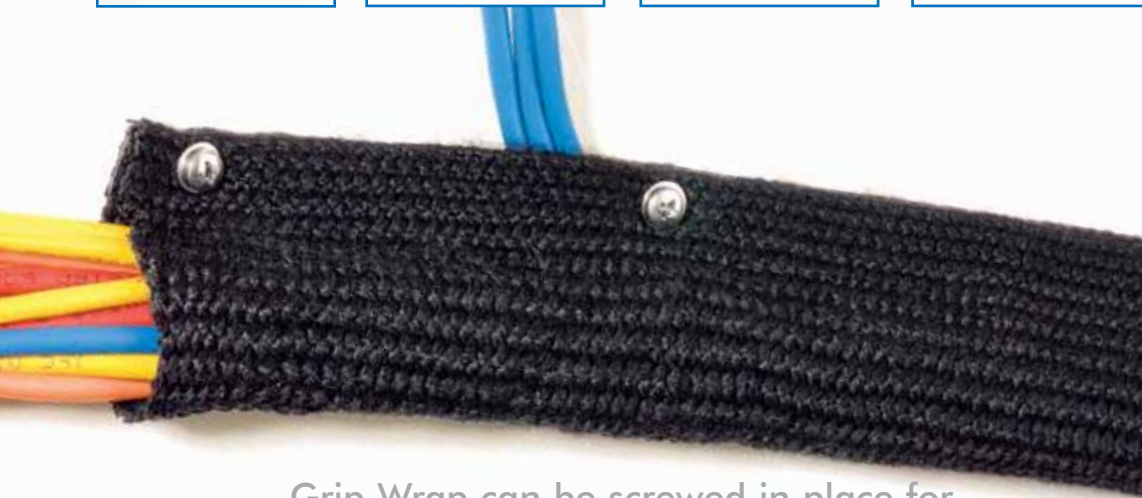

Grip Wrap can be screwed in place for a permanent wire duct.

Nominal Size	Part #	Flat Width	Standard Spool Put-Ups		Available Colors	Lbs/100'
			Bulk Spool	Shop Spool		
3/4"	GWN0.75BK	2 15/16"	100'	25'	Black (BK)	2.00
1"	GWN1.00BK	4 7/16"	100'	25'	Black (BK)	3.00
1 3/8"	GWN1.38BK	5 5/16"	100'	25'	Black (BK)	4.00



Soft sleeve for reduced noise on floors and in studios.



Heavy Wall

- 950 Cycles*
- Braided from 15 mil PET Monofilament
- Extreme Abrasion & Cut Resistance
- UV Resistant
- Resists Gasoline, Solvents, Salt Water and Chemicals
- Temp. Range -94°F to 257°F
- Melt Temp. 482°F

50% Thicker for The Really Abrasive Jobs

When your application calls for more protection than our 10 mil products provide, our 15 mil FLEXO HEAVY WALL (HW) is the ideal solution.

HW is commonly used in industrial and marine applications where extreme abrasion protection is critical. The durability of HW makes it ideal for protecting hoses and cables that have to withstand constant contact with rough and abrasive surfaces.

HW is the perfect solution for use on hoses, cables and chains to protect painted or laminated surfaces from scuffing and wear.

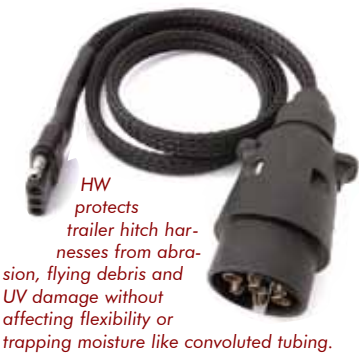

MARINE INDUSTRY PROVEN FOR OVER 30 YEARS

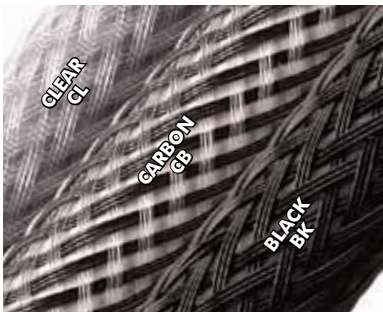

Nominal Size	Part #	Expansion Range		Standard Spool Put-Ups		Available Colors	Lbs/100'
		Min.	Max.	Bulk Spool	Shop Spool		
3/8"	HWN0.38	3/16"	3/4"	500'	100'	CL, CB & BK	0.82
5/8"	HWN0.63	5/16"	7/8"	250'	75'	CL, CB & BK	1.10
1"	HWN1.00	1/2"	1 1/2"	250'	50'	CL, CB & BK	1.60
1 1/2"	HWN1.50	3/4"	2"	250'	50'	CL, CB & BK	2.50
2"	HWN2.00	1 1/2"	3"	200'	50'	CL, CB & BK	3.40
3"	HWN3.00	2"	4"	100'	50'	CL, CB & BK	4.20
4"	HWN4.00	2 1/2"	5 1/2"	100'	50'	CL, CB & BK	6.50

800 323-5140
www.techflex.com



*Abrasion Resistance

630	950	2,500	3,500	4,400	8,500	13,000
-----	-----	-------	-------	-------	-------	--------

HIGH

EXTREMELY HIGH





Flexo Super Duty

Heavy Duty, Light Weight & Flexible

FLEXO SUPER DUTY (SD) is braided from 20 mil Nylon® 6-6 Polyamide monofilament. Heavy duty and flexible, this sleeving is extremely versatile. Excellent durability makes SD ideal for a wide range of industrial applications and other jobs where high abrasion protection is needed.

Super Duty outperforms all competitive round filament sleeving. SD is also more economical and easy to use, cutting cleanly with a hot knife leaving a neat, sealed end.



- **2,500 Cycles***
- **Braided from 20 Mil Nylon Monofilament**
- **High Coverage**
- **Extreme Abrasion and Cut Resistance**
- **Resists Gasoline, UV, Solvents, Salt Water, and Chemicals**

Super Duty protects harnesses & hydraulic hoses from abrasion & flying debris without affecting flexibility or trapping moisture.



Nominal Size	Part #	Expansion Range		Standard Spool Put-Ups		Available Colors	Lbs/100'
		Min.	Max.	Bulk Spool	Shop Spool		
1/4"	SDN0.25BK	1/4"	1/2"	500'	100'	Black (BK)	1.05
1/2"	SDN0.50BK	1/2"	1"	250'	100'	Black (BK)	1.85
3/4"	SDN0.75BK	3/4"	1 1/4"	250'	50'	Black (BK)	2.30
1"	SDN1.00BK	1"	1 1/2"	250'	50'	Black (BK)	2.75
1 1/4"	SDN1.25BK	1 1/4"	2"	250'	50'	Black (BK)	3.00
1 3/4"	SDN1.75BK	1 3/4"	2 3/4"	100'	25'	Black (BK)	4.00
2 1/4"	SDN2.25BK	2 1/4"	3"	100'	25'	Black (BK)	5.30



Beats all competition in its class in head-to-head abrasion testing.



*Abrasion Resistance

630	950	2,500	3,500	4,400	8,500	13,000
HIGH			EXTREMELY HIGH			



800 323-5140
www.techflex.com



Gorilla

- **4,400 Cycles***
- **Flat Filament Technology**
- **Smooth Feel and Reduced Drag**
- **Resists Damage from UV, Gasoline, Engine Chemicals, and Salt Water**
- **Extreme Cut and Abrasion Resistance**

Innovative Flat Filament Braided for High Abrasion Resistance

GORILLA SLEEVE (NH) is engineered from flat filaments of tough and strong 6-6 Nylon to achieve a thick abrasion guard for use on hoses. This type of sleeve has been tested against competitors abrasion guards that mix materials in an effort to gain slight abrasion advantages.

Gorilla Sleeve achieves better results without sacrificing great looks or flexibility.



50 mil flat monofilament



10 mil round monofilament



Comparison of monofilaments: flat versus round (magnified for better visibility)



Constant abuse from abrasion and vibration make Gorilla Sleeve the choice to protect hoses on excavators and heavy equipment.

Nominal Size	Part #	Expansion Range		Standard Spool Put-Ups		Available Colors	Lbs/100'
		Min.	Max.	Bulk Spool	Shop Spool		
1/2"	NHN0.50BK	3/8"	5/8"	500'	100'	Black (BK)	1.40
3/4"	NHN0.75BK	5/8"	1"	250'	50'	Black (BK)	2.10
1"	NHN1.00BK	7/8"	1 1/4"	250'	50'	Black (BK)	2.20
1 1/4"	NHN1.25BK	1"	1 1/2"	250'	50'	Black (BK)	2.50
1 3/4"	NHN1.75BK	1 1/2"	2"	100'	25'	Black (BK)	4.00
2"	NHN2.00BK	1 3/4"	2 1/2"	100'	25'	Black (BK)	4.40

800 323-5140
www.techflex.com



*Abrasion Resistance

630	950	2,500	3,500	4,400	8,500	13,000
-----	-----	-------	-------	-------	-------	--------

HIGH

EXTREMELY HIGH





Dura-Wrap

Harsh Environment Protection with Easy On, Easy Off Hook & Loop Closure

DURA WRAP (DW) is the answer to organizing and controlling wires, cables and hoses that are subjected to constant and extreme use. The flexible sleeve is made from tightly woven ballistic Nylon with an aggressive, industrial strength hook and loop closure. DURA WRAP is used on wires to keep them together, on hoses and cables to prevent abrasion damage or on chains to keep them from ruining expensive finished surfaces.

Dura Wrap reduces expensive downtime thanks to it's easy retro fit installation. No disassembly required.

DW is extremely flexible and easy to install over single or multiple hoses. In the event of a hose rupture, the high strength sleeving helps prevent high pressure fluid from becoming a danger to equipment operators and other personnel.

- **8,500 Cycles***
- **Tightly Woven Ballistic Nylon Construction**
- **Heavy Duty, Oversize Hook & Loop Closure**
- **Repels Liquids**
- **Easy Retro Fit Installation**



DW is perfect for protecting hydraulic pistons in harsh environments.

Nominal Size	Part #	Wall Thickness	Hook & Loop Width	Standard Spool Put-Ups		Available Colors	Lbs/100'
				Bulk Spool	Shop Spool		
1"	DWN1.00BK	.026"	1"	150'	25'	Black (BK)	0.82
1 1/2"	DWN1.50BK	.026"	1"	150'	25'	Black (BK)	1.10
2"	DWN2.00BK	.026"	1"	150'	25'	Black (BK)	1.60
2 1/2"	DWN2.50BK	.026"	1"	150'	25'	Black (BK)	2.50
3"	DWN3.00BK	.026"	1"	50'	25'	Black (BK)	3.40
3 1/2"	DWN3.50BK	.026"	1"	50'	25'	Black (BK)	4.20
4"	DWN4.00BK	.026"	1"	50'	25'	Black (BK)	6.50
4 1/2"	DWN4.50BK	.026"	1"	50'	25'	Black (BK)	8.30
6"	DWN6.00BK	.026"	1"	50'	25'	Black (BK)	21.00



*Abrasion Resistance

630	950	2,500	3,500	4,400	8,500	13,000
HIGH				EXTREMELY HIGH		

800 323-5140
www.techflex.com



Dura-Flex

- **3,500 Cycles***
- **45 Mil Wall Thickness Resists Snagging**
- **Prevents Damage From UV, Gasoline, Engine Chemicals and Salt**
- **Resists Cuts, Abrasion and Penetration**
- **Flexible & Economical General Purpose Protection**
- **Install Easily during Production or Repair**
- **Deflects High Pressure Hose Ruptures**

Industrial Hose & Cable Protection for Harsh Environments

The tightly woven Nylon makes DURA FLEX (DF) the perfect solution for hose & cable protection. The 45 mil wall thickness will protect cables, hoses and ropes from weather, sunlight and abrasion damage.

When installed over uncoated cable or chains, DF will prevent scraping, chafing and contact damage to painted or other fragile surfaces.

DF is resistant to chemicals, UV damage and rot, and is suitable for continuous outdoor use under all weather conditions. The flexible sleeving cuts with a scissor and the tight construction slides easily over any application.



Multiple high pressure hoses can be bundled tightly together to protect them from abrasion and weather, and to protect personnel from potential harm due to high pressure rupture.

Nominal Size	Part #	Wall Thickness	Standard Spool Put-Ups			Available Colors	Lbs/100'
			Maxi Coil	Bulk Spool	Shop Spool		
0.71"	DFN0.71BK	.045"	300'	100'	50'	Black (BK)	2.57
0.83"	DFN0.83BK	.045"	300'	100'	50'	Black (BK)	2.58
0.92"	DFN0.92BK	.045"	300'	100'	50'	Black (BK)	3.22
1.00"	DFN1.00BK	.045"	300'	100'	50'	Black (BK)	3.66
1.13"	DFN1.13BK	.045"	300'	100'	50'	Black (BK)	4.18
1.25"	DFN1.25BK	.045"	300'	100'	50'	Black (BK)	4.49
1.34"	DFN1.34BK	.045"	300'	100'	50'	Black (BK)	4.84
1.59"	DFN1.59BK	.045"	300'	100'	50'	Black (BK)	5.37
1.75"	DFN1.75BK	.045"	300'	100'	50'	Black (BK)	6.13
2.07"	DFN2.07BK	.045"	300'	100'	50'	Black (BK)	7.26
2.38"	DFN2.38BK	.045"	300'	100'	50'	Black (BK)	8.28
2.54"	DFN2.54BK	.045"	300'	100'	50'	Black (BK)	8.98
2.86"	DFN2.86BK	.045"	300'	100'	50'	Black (BK)	9.89
3.34"	DFN3.34BK	.045"	300'	50'	25'	Black (BK)	11.59
3.66"	DFN3.66BK	.045"	300'	50'	25'	Black (BK)	12.25

800 323-5140
www.techflex.com

*Abrasion Resistance						
630	950	2,500	3,500	4,400	8,500	13,000
HIGH				EXTREMELY HIGH		





Dura-Flex Pro

Most Advanced Hose Protection Solution

DURA FLEX PROFESSIONAL (DP) provides tough hose protection two ways. First, per the ISO 6945 spec, DP's unique 80 mil thick tubular weave design will withstand up to 13,000 abrasion cycles without wearing through the fabric at any location.

Additionally, the exceptionally smooth inner wall provides easy installation and minimizes any internal abrasion problems. The tightly woven Nylon construction is extremely flexible and resists chemical and ultraviolet degradation.

Dura-Flex Professional cuts with a scissor, installs quickly and easily.

DP is perfect for industrial and construction applications where adequate protection is needed.

- **13,000 Cycles***
- **Heavy Duty, 80 Mil Wall Thickness**
- **ISO 6945 Certified**
- **Professional Grade Construction**
- **Smooth Inner Wall Prevents Internal Abrasion Damage**
- **Nylon Construction Resists UV, Salt, Chemicals, Vermin, and Rot**



Techflex Dura Flex products add increased safety in confined spaces such as mines.



Whatever your hose or application, DP will provide an extra level of protection from cuts, abrasion and UV damage.

Nominal Size	Part #	Wall Thickness	Standard Spool Put-Ups		Available Colors	Lbs/100'
			Bulk Spool	Shop Spool		
0.75"	DPN0.75BK	.08"	100'	50'	Black (BK)	4.43
0.93"	DPN0.93BK	.08"	100'	50'	Black (BK)	5.51
1.13"	DPN1.13BK	.08"	100'	50'	Black (BK)	7.15
1.25"	DPN1.25BK	.08"	100'	50'	Black (BK)	7.44
1.35"	DPN1.35BK	.08"	100'	50'	Black (BK)	8.02
1.43"	DPN1.43BK	.08"	100'	50'	Black (BK)	8.32
1.63"	DPN1.63BK	.08"	100'	50'	Black (BK)	9.53
1.81"	DPN1.81BK	.08"	100'	50'	Black (BK)	10.71
2.19"	DPN2.19BK	.08"	100'	50'	Black (BK)	12.31
2.63"	DPN2.63BK	.08"	100'	50'	Black (BK)	14.83
2.88"	DPN2.88BK	.08"	100'	50'	Black (BK)	17.30
3.13"	DPN3.13BK	.08"	50'	25'	Black (BK)	18.04
3.38"	DPN3.38BK	.08"	50'	25'	Black (BK)	20.11
3.63"	DPN3.63BK	.08"	50'	25'	Black (BK)	21.60
4.00"	DPN4.00BK	.08"	50'	25'	Black (BK)	23.52



*Abrasion Resistance						
630	950	2,500	3,500	4,400	8,500	13,000
HIGH				EXTREMELY HIGH		

800 323-5140
www.techflex.com

Metal Braid

- EMI, RFI, ESD Protection
- Grounding Straps
- Engine Dress-Up
- Complies with CID A-A-59569
- Extreme Blowout Protection
- Expands for Easy Installation
- Cut and Abrasion Resistant

Tinned Copper Sleeve for Shielding, Grounding and Decoration

Our skill with braided sleeving extends to many materials including metal braid for a variety of applications. Our Tinned Copper METAL BRAID (MB) is perfect for shielding on harnesses and cables. Wire conforms to ASTM-B 33.

High end automotive applications have always used braided metal for secure and efficient grounding applications. The material is also great for hose covering on hot rods and motorcycles.

Cutting Instructions



To prevent fraying when cutting any metal braid, slip the sleeving over the intended application to get an accurate measurement, wrap the area to be cut with a couple of turns of tape, mark the cut and remove the sleeving. Use shears or serrated scissors to cut through the tape and sleeving. Don't remove the tape until the sleeving is installed and you're ready to terminate the end.



Nominal Size	Part #	AWG of Ends	Carriers	Wires per Carrier	Current Capacity Amps	Standard Spool Put-Ups		Available Colors	Lbs/ 100'
						Bulk Spool	Shop Spool		
*5/32"	MBN0.16SV	36	24	10	40	250'	100'	Silver (SV)	2.10
*1/4"	MBN0.25SV	36	24	16	53	250'	100'	Silver (SV)	2.20
*3/8"	MBN0.38SV	36	48	8	53	250'	100'	Silver (SV)	3.30
*1/2"	MBN0.50SV	36	48	11	62	100'	50'	Silver (SV)	3.50
5/8"	MBN0.63SV	34	48	8	64	100'	50'	Silver (SV)	3.60
*25/32"	MBN0.78SV	36	48	18	88	100'	50'	Silver (SV)	7.35
*7/8"	MBN0.88SV	30	48	7	100	100'	50'	Silver (SV)	10.30
*1"	MBN1.00SV	30	48	8	120	100'	50'	Silver (SV)	13.15
*1 1/8"	MBN1.13SV	30	48	9	130	100'	50'	Silver (SV)	13.80
*1 3/8"	MBN1.38SV	30	48	11	150	100'	50'	Silver (SV)	16.90
*1 1/2"	MBN1.50SV	30	48	12	165	100'	50'	Silver (SV)	18.40
2 1/4"	MBN2.25SV	30	48	16	190	100'	50'	Silver (SV)	23.60
Heavy Duty Construction									
*1/2"	MBH0.50SV	30	24	15	120	100'	50'	Silver (SV)	12.00

*Complies with CID A-A-59569 (formerly Mil Spec QQB-575).
Contact an Account Representative for additional sizes.



Flexo Stainless

Braided Stainless Steel, Pre-Rounded for Installation Ease

Nothing protects hoses from wear and blowout quite like real STAINLESS STEEL (SS) braid. It looks great in any application and is as strong as steel. But, custom hoses overbraided with stainless steel are expensive, selections are often limited and production and delivery times can be an issue.

Now, you can take any stock or custom hose, slip a length of Flexo Stainless over it, hide the cut ends under your clamps and have the same look and protection as custom overbraided hoses at a fraction of the cost.

Flexo Stainless cuts with shears or serrated scissors (pg. 73), is pre-rounded for easy, slip on installation and is available in diameters and expansion ranges to accommodate virtually any common hose or wire application.

Our new X-tra coverage product, Stainless Steel XC, provides fuller coverage and results in continuous stainless steel shine.

- **Virtually Indestructible 304 Stainless Steel**
- **Won't Discolor or Rust**
- **Easy to Install**
- **Cuts with Shears or Serrated Scissors**
- **Resists Abrasion, Chemicals and UV**
- **Improves Burst Strength of Hoses**

Stainless Steel sleeving is used in applications such as expansion joints, where constant movement and high temperatures require a flexible, indestructible covering.



Flexo Stainless Steel

Nominal Size	Part #	Wall Thickness	Expansion Range		Standard Spool Put-Ups		Available Colors	Lbs/100'
			Min.	Max.	Bulk Spool	Shop Spool		
1/2"	SSN0.50SV	.025"	1/4"	5/8"	100'	25'	Silver (SV)	4.00
5/8"	SSN0.63SV	.025"	3/8"	3/4"	100'	25'	Silver (SV)	5.00
3/4"	SSN0.75SV	.025"	1/2"	1"	100'	25'	Silver (SV)	5.00
1"	SSN1.00SV	.025"	3/4"	1 1/4"	100'	25'	Silver (SV)	11.00
1 1/4"	SSN1.25SV	.035"	1"	1 1/2"	100'	25'	Silver (SV)	19.00
1 3/4"	SSN1.75SV	.040"	1 1/2"	2 1/4"	100'	25'	Silver (SV)	31.00



Stainless Steel XC gives a full coverage on any application and slides onto hoses for that custom look.

Flexo Stainless Steel XC

Nominal Size	Part #	Wall Thickness	Expansion Range		Standard Spool Put-Ups		Available Colors	Lbs/100'
			Min.	Max.	Bulk Spool	Shop Spool		
1/4"	SSL0.25SV	.013"	3/16"	13/32"	250'	100'	Silver (SV)	2.20
3/8"	SSL0.38SV	.013"	1/4"	5/8"	250'	100'	Silver (SV)	2.54
1/2"	SSL0.50SV	.013"	3/8"	3/4"	100'	50'	Silver (SV)	3.15
3/4"	SSL0.75SV	.013"	1/2"	1 1/4"	100'	50'	Silver (SV)	6.90
1"	SSL1.00SV	.025"	5/8"	1 5/16"	100'	50'	Silver (SV)	9.78
1 1/4"	SSL1.25SV	.025"	3/4"	1 3/4"	100'	50'	Silver (SV)	13.70
1 1/2"	SSL1.50SV	.025"	1"	2 1/8"	100'	50'	Silver (SV)	16.60



High end automotive applications have always used stainless steel hoses for looks, protection and durability.





Flexo Shield

- **Excellent EMI Shielding (1 MHz to 1 GHz)**
- **Flame Retardant**
- **Easy to Install**
- **Cut and Abrasion Resistant**
- **Extremely Flexible and Lightweight**
- **Temperature Range -40°F to 302°F**
- **Cuts Easily with Scissors**

Light Weight Shielded Expandable Sleeving

FLEXO SHIELD (FS) is a high performance EMI (Electromagnetic Interference) shield, braided expandable sleeving style. Flexo Shield is cut and abrasion resistant, flexible and lightweight. With its high temperature Aramid fiber core and special construction, Flexo Shield can expand and contract to create a perfect fit. Flexo Shield braided fibers create a sleeve that provides good EMI protection, high coverage, and easy installation.

Techflex Flexo Shield is great for applications where light weight and high performance are needed. Such applications may include computer systems, electronic office equipment, medical electronics, communication systems and many more. The product is intended for high flex, high temperature, and environmentally tough conditions, therefore making it appropriate for several aerospace applications.

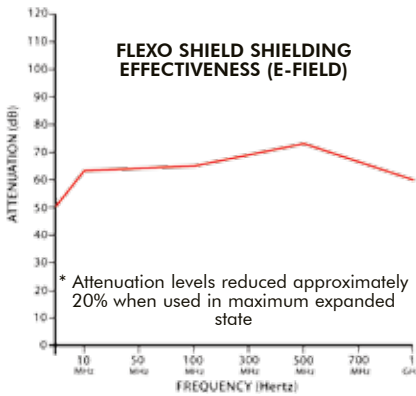

Attenuation data was derived using procedures defined in Mil-STD-295.



Flexo Shield can provide end-to-end shielding solution on your application.



Nominal Size	Part #	Expansion Range		Standard Spool Put-Ups		Available Colors	Lbs/100'
		Min.	Max.	Bulk Spool	Shop Spool		
1/8"	FSN0.13SV	1/16"	1/4"	328'	164'	Silver (SV)	0.74
3/8"	FSN0.38SV	1/4"	1/2"	328'	164'	Silver (SV)	1.38
1/2"	FSN0.50SV	3/8"	3/4"	328'	164'	Silver (SV)	2.09
3/4"	FSN0.75SV	1/2"	1"	328'	164'	Silver (SV)	2.80
1"	FSN1.00SV	3/4"	1 1/4"	328'	164'	Silver (SV)	
1 1/4"	FSN1.25SV	1"	1 1/2"	328'	164'	Silver (SV)	
1 1/2"	FSN1.50SV	1 1/4"	1 3/4"	328'	164'	Silver (SV)	



Flexo Conductive

Conductive Carbon Infused Nylon for Static Protection and Shielding

FLEXO CONDUCTIVE (CN) is braided from 11 mil carbonized Nylon monofilament yarn. Flexo Conductive is designed to protect sensitive wiring from abrasion while shielding it from high frequency noise. Many successful applications have utilized this sleeving for maintaining clean video signals, interference filtering in pro sound environments, and RF filtering on power cables and outputs. CN is also useful in static sensitive environments.

Flexo Conductive utilizes a patented carbonization process which infuses our braided sleeving with a microscopic carbon compound that is virtually indistinguishable from the base material. The result is a strong, long lasting jacket that is ready for the most sensitive applications.

- **EMI, RFI Protection**
- **ESD Management Solution**
- **Economical and Easy to Install**
- **Cut & Abrasion Resistant**
- **Expands up to 150%**
- **Halogen Free**
- **Resists Gasoline and Engine Chemicals**



Clean signals without excessive noise can be achieved with properly isolated cables and wires.

"Techflex assures maximum protection for delicate video and data lines".

Tim Daly - Emmy Award Winning Engineer
InterTest - www.intertestinc.com

Nominal Size	Part #	Expansion Range		Standard Spool Put-Ups		Available Colors	Lbs/100'
		Min.	Max.	Bulk Spool	Shop Spool		
1/8"	CNN0.13BK	3/32"	1/4"	1,000'	225'	Black (BK)	0.18
1/4"	CNN0.25BK	1/8"	7/16"	1,000'	200'	Black (BK)	0.23
3/8"	CNN0.38BK	3/16"	5/8"	500'	125'	Black (BK)	0.51
1/2"	CNN0.50BK	1/4"	3/4"	500'	100'	Black (BK)	0.68
5/8"	CNN0.63BK	3/8"	1"	500'	100'	Black (BK)	0.96
3/4"	CNN0.75BK	1/2"	1 1/4"	250'	75'	Black (BK)	1.00
1"	CNN1.00BK	5/8"	1 5/8"	250'	65'	Black (BK)	1.20
1 1/4"	CNN1.25BK	3/4"	1 3/4"	250'	50'	Black (BK)	1.65
1 1/2"	CNN1.50BK	1"	2 1/2"	200'	40'	Black (BK)	2.20



800 323-5140
www.techflex.com

Clean Cut FR

- **VW-1, Mil-202 Approved**
- **Cut and Abrasion Resistant**
- **Expands for Ease of Installation**
- **Halogen Free**
- **Temperature Range -94°F to 257°F**
- **Melt Temp. 482°F**

Scissor Cut for Field Installation, Will Not Support Combustion

CLEAN CUT FLAME RETARDANT (CC) has all of the same qualities that make our standard CC so easy to cut and install, with the added advantage of a flame inhibitor to provide an extra level of safety in certain applications.

Under normal conditions, Clean Cut FR will quickly self-extinguish and minimize flame spread and incidental damage to surrounding components.

The combination of flame retardance, ease of installation and nearly complete coverage makes Clean Cut FR an ideal solution for many industrial and advanced engineering applications.



Pro AV installers can incorporate CCF into cabling designs for concert, studio and nightclub installations.



Nominal Size	Part #	Expansion Range		Standard Spool Put-Ups		Available Colors	Lbs/100'
		Min.	Max.	Bulk Spool	Shop Spool		
1/8"	CCF0.13	1/8"	1/4"	1,000'	100'	TW & TB	0.40
1/4"	CCF0.25	5/32"	7/16"	1,000'	100'	TW & TB	0.46
3/8"	CCF0.38	3/16"	5/8"	500'	100'	TW & TB	0.74
1/2"	CCF0.50	1/4"	3/4"	500'	100'	TW & TB	0.82
3/4"	CCF0.75	5/8"	1"	250'	75'	TW & TB	1.11
1"	CCF1.00	3/4"	1 3/16"	250'	50'	TW & TB	1.24
1 1/4"	CCF1.25	1"	1 1/2"	250'	50'	TW & TB	1.56
1 1/2"	CCF1.50	1 1/4"	2"	250'	50'	TW & TB	1.85



Flexo FR

Flame Retardant, Economical Sleeving Solution

FLEXO PET FLAME RETARDANT (FR) sleeving is the perfect choice for electronic and high tech applications where flame retardance and durability are primary concerns. Ease of installation makes Flexo FR an efficient choice for long runs of wire or cable.

The addition of an organic combustion inhibitor to our standard polyethylene terephthalate gives Flexo FR an Underwriters Lab and CSA flame resistance rating of VW-1.

- **VW-1 Approved**
- **Mil-202, FAR 25, FMVSS 302**
- **Economical and Easy to Install**
- **Cut and Abrasion Resistant**
- **Expands up to 150%**
- **Halogen Free**
- **Resists Gasoline and Engine Chemicals**
- **Temperature Range -94°F to 257°F**
- **Melt Temp. 482°F**



Nominal Size	Part #	Expansion Range		Standard Spool Put-Ups		Available Colors	Lbs/100'
		Min.	Max.	Bulk Spool	Shop Spool		
1/8"	FRN0.13	3/32"	1/4"	1,000'	225'	SP, TW, TB & GW	0.16
1/4"	FRN0.25	1/8"	7/16"	1,000'	200'	SP, TW, TB & GW	0.24
3/8"	FRN0.38	3/16"	1/2"	500'	125'	SP, TW, TB & GW	0.57
1/2"	FRN0.50	1/4"	3/4"	500'	100'	SP, TW, TB & GW	0.72
3/4"	FRN0.75	1/2"	1 1/4"	250'	75'	SP, TW, TB & GW	0.87
1"	FRN1.00	5/8"	1 5/8"	250'	65'	SP, TW, TB & GW	1.34
1 1/4"	FRN1.25	3/4"	1 3/4"	250'	50'	SP, TW, TB & GW	1.60
1 1/2"	FRN1.50	1"	2 1/8"	200'	40'	TW, TB & GW	1.96
1 3/4"	FRN1.75	1 1/4"	2 3/4"	200'	30'	SP, TW, TB & GW	2.70
2"	FRN2.00	1 1/2"	3 1/2"	200'	50'	SP, TW, TB & GW	3.30
2 1/2"	FRN2.50	1 3/4"	3 5/8"	200'	50'	SP, TW, TB & GW	3.80
3"	FRN3.00	2 1/2"	4 3/4"	100'	50'	TW, TB & GW	4.00
3 End Construction							
1/4"	FR30.25TB	1/8"	3/8"	1,000'	200'	TB	0.39





Liquid Wrap

- **Water Repellent When Properly Sealed**
- **Will Not Support Growth of Bacteria**
- **Disinfects Easily**
- **Adhesive Resists Most Cleaners and Disinfectants**

Stylish Fluid Protection For Wires & Cables

Our new L6 LIQUID WRAP semi-rigid wrap-around sleeving is engineered from tough braided polyester, and laminated with a layer of strong Mylar sheeting. This combination provides a strong and lightweight solution for any application that requires protection from repeated exposure to the elements.

The wraparound construction, with 12% edge overlap makes installation easy over existing assemblies or harnesses, and the extra wide adhesive strip ensures a positive, aggressive seal against damage from exposure.

L6 is available in 4' pre-cut sticks in Black or White.



The fluid resistance of Liquid Wrap sleeve makes it ideal for cable management in medical applications.



L6 is ideal for marine and automotive wiring harnesses.



Nominal Size	Wall Thickness	Part #	4' Pcs. Put-Ups				Available Colors	Lbs/10Pcs.
			Bulk Box	Box 8x8	Box 6x6	Box 4x4		
3/8"	.046"	L6N0.38	250	90	50	30	Black (BK) & White (WH)	0.9
1/2"	.046"	L6N0.50	250	70	40	25	Black (BK) & White (WH)	1.0
3/4"	.046"	L6N0.75	125	50	30	15	Black (BK) & White (WH)	1.8
1"	.046"	L6N1.00	88	30	20	9	Black (BK) & White (WH)	2.2
1 1/4"	.046"	L6N1.25	63	20	10	6	Black (BK) & White (WH)	2.6





Flexo F6 FR

Flexible, Semi-Rigid Split Sleeving Will Not Support Combustion

Flame spread is a vital safety consideration in applications as diverse as home built aircraft wiring and safely managing sound & lighting cables at clubs, concerts and theaters. To address these issues, and to provide unequalled flexibility and access, we have developed this unique sleeving product.

Self-extinguishing F6F fully complies with UL standard VW-1. The addition of an organic flame inhibitor to our triaxially braided F6 split sleeving provides the perfect solution to a wide range of cable management needs.

Easy slip over installation, complete access along the entire run, economy, durability and UL certified flame retardance make F6F ideal when the goal is to manage wires and cables safely and effectively.



- **VW-1, FAR 25**
- **Wraparound Without Fasteners**
- **Temperature Range -94°F to 257°F**
- **Melt Temp. 446°F**

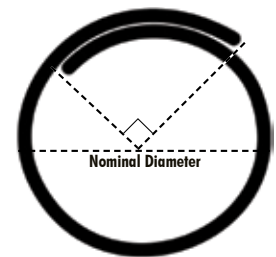

The large overlap allows easy installation over splices and inline connectors without exposing wires and cables.



Accepted for use by major aircraft manufacturers.

Nominal Size	Part #	Wall Thickness	Standard Spool Put-Ups			Available Colors	Lbs/100'
			Bulk Box	Box A	Box B		
1/8"	F6F0.13TB	.024"	10,000'	400'	100'	Black w/White Tracer (TB)	0.20
1/4"	F6F0.25TB	.025"	3,000'	200'	100'	Black w/White Tracer (TB)	0.60
3/8"	F6F0.38TB	.025"	1,000'	150'	75'	Black w/White Tracer (TB)	1.20
1/2"	F6F0.50TB	.025"	1,200'	150'	75'	Black w/White Tracer (TB)	1.40
3/4"	F6F0.75TB	.025"	500'	100'	50'	Black w/White Tracer (TB)	1.60
1"	F6F1.00TB	.038"	400'	100'	50'	Black w/White Tracer (TB)	2.00
1 1/4"	F6F1.25TB	.038"	250'	75'	25'	Black w/White Tracer (TB)	2.40
1 1/2"	F6F1.50TB	.038"	200'	75'	25'	Black w/White Tracer (TB)	2.70
2"	F6F2.00TB	.038"	150'	50'	25'	Black w/White Tracer (TB)	3.60



Flexo Wrap FR

- **VW-1, Mil-202, Approved**
- **Economical and Easy to Install**
- **Cut and Abrasion Resistant**
- **Hook and Loop Closure For Easy and Repeatable Access**
- **Temperature Range -94°F to 257°F**
- **Melt Temp. 482°F**

Easy On, Easy Off Access Will Not Support Combustion

FLAME RETARDANT FLEXO WRAP (FWF) provides the same hook and loop wire management flexibility as our standard Flexo Wrap along with the added safety feature of an organic flame inhibitor to provide an additional level of security.

FWF is a safe, economical solution for a wide range of cable management applications where moderate levels of flame protection are needed.



FLEXO WRAP FR is designed for quick and easy management of wire, cable and hose assemblies. Just separate the hook and loop fasteners along the edge of the material....



and slip the entire length of FW around or under your harness or component assembly. The wide expandability range allows FW to easily fit around...



odd-shaped connectors and gently constrict around the diameter of your wires. When the FW is in place, simply seal the hook and loop along the edges.

Nominal Size	Part #	Hook & Loop Width	Standard Spool Put-Ups		Available Colors	Lbs/100'
			Bulk Spool	Shop Spool		
1/2"	FWF0.50TB	1/4"	100'	20'	Black w/White Tracer (TB)	1.30
3/4"	FWF0.75TB	5/8"	100'	15'	Black w/White Tracer (TB)	1.80
1 1/4"	FWF1.25TB	5/8"	100'	12'	Black w/White Tracer (TB)	2.30
2"	FWF2.00TB	5/8"	100'	10'	Black w/White Tracer (TB)	3.20
2 1/2"	FXF2.50TB	5/8"	100'	10'	Black w/White Tracer (TB)	3.75

800 323-5140
www.techflex.com





Flexo Tight Weave FR

Tight Braid For Fuller Coverage

FLEXO TIGHT WEAVE FLAME RETARDANT sleeving was developed by and for aircraft manufacturers as a replacement for the Standard Grade FR. This sleeving material is constructed from tightly braided 9 mil flame retardant monofilament. The result is fuller coverage over wire harnesses. This allows for increased abrasion protection, which is a critical issue in the aviation industry.

The 9 mil monofilament is used instead of 10 mil in order to lessen the additional weight that results when the monofilament is tightly braided into sleeving material. We manufacture additional diameters to accommodate various wire harnesses up to 3" in diameter.



- **VW-1, Mil-202, FAR 25 Approved**
- **Cut and Abrasion Resistant**
- **Halogen Free**
- **Resists Gasoline and Engine Chemicals**
- **Temperature Range -94°F to 257°F**
- **Melt Temp. 482°F**



Meets material specs for major airlines.

Nominal Size	Part #	Expansion Range		Standard Spool Put-Ups		Available Colors	Lbs/100'
		Min.	Max.	Bulk Spool	Shop Spool		
1/8"	F9T0.13TB	1/16"	7/32"	1,000'	225'	Black w/White Tracer (TB)	0.27
1/4"	F9T0.25TB	9/64"	13/32"	1,000'	200'	Black w/White Tracer (TB)	0.32
5/16"	F9T0.31TB	3/16"	7/16"	500'	125'	Black w/White Tracer (TB)	0.48
1/2"	F9T0.50TB	9/32"	5/8"	500'	100'	Black w/White Tracer (TB)	0.74
9/16"	F9T0.56TB	3/8"	5/8"	500'	100'	Black w/White Tracer (TB)	0.63
3/4"	F9T0.75TB	1/2"	1"	500'	75'	Black w/White Tracer (TB)	0.97
1"	F9T1.00TB	5/8"	1 1/4"	250'	65'	Black w/White Tracer (TB)	1.26
1 1/4"	F9T1.25TB	3/4"	1 3/4"	250'	50'	Black w/White Tracer (TB)	2.03
1 1/2"	F9T1.50TB	1"	1 7/8"	250'	40'	Black w/White Tracer (TB)	2.32
1 3/4"	F9T1.75TB	1 5/16"	2 3/16"	250'	30'	Black w/White Tracer (TB)	2.61
2"	F9T2.00TB	1 7/16"	2 3/8"	200'	50'	Black w/White Tracer (TB)	3.02
2 1/4"	F9T2.25TB	1 3/4"	2 11/16"	200'	50'	Black w/White Tracer (TB)	3.04
2 1/2"	F9T2.50TB	1 7/8"	3"	200'	50'	Black w/White Tracer (TB)	3.69



Lighter weight than standard tight weaves.



Halar

- Meets **UL 2024**
- **VW-1, FAR 25** Approved
- Easy to Install
- Cut and Abrasion Resistant
- Expands up to 150%
- Resists Gasoline and Engine Chemicals
- Temperature Range **-103°F to 302°F**
- Melt Temp. **482°F**

Very Low Outgassing, Self-Extinguishing UL-2024 Plenum Rated Sleeving

HALAR® (HT) self-extinguishing sleeving is used where flammability, high temperature endurance and low outgassing are primary concerns. HT is braided from 11 mil ethylene chlorotrifluoroethylene (ECTFE) copolymer monofilament. Because of its low flame spread and smoke generation properties, HT meets UL 2024 and NFPA 262 plenum specifications, UL flame resistance rating of VW-1 and exceeds automotive industry requirements of FMVSS 302, as well as aviation industry requirements of FAR 25.

HT resists a wide range of corrosive chemicals and organic solvents, including strong acids, chlorine and aqueous caustics. HALAR® ECTFE also maintains useful properties on exposure to cobalt 60 radiation at doses up to 200 megarads.



Halar's low outgassing, as well as its heat, chemical and radiation properties, make it ideal for use as a component in technologically advanced applications.



UL 2024 supersedes UL 910 standard for Cable Management products.



Nominal Size	Part #	Expansion Range		Standard Spool Put-Ups		Available Colors	Lbs/100'
		Min.	Max.	Bulk Spool	Shop Spool		
1/8"	HTN0.13	3/32"	1/4"	1,000'	225'	TW & TB	0.25
1/4"	HTN0.25	1/8"	7/16"	1,000'	200'	TW & TB	0.38
3/8"	HTN0.38	3/16"	5/8"	500'	125'	TW & TB	0.86
1/2"	HTN0.50	1/4"	3/4"	500'	100'	TW & TB	1.10
3/4"	HTN0.75	1/2"	1 1/4"	250'	75'	TW & TB	1.70
1"	HTN1.00	5/8"	1 5/8"	250'	65'	TW & TB	2.20
1 1/4"	HTN1.25	3/4"	1 3/4"	250'	50'	TW & TB	2.60
1 3/4"	HTN1.75	1 1/4"	2 3/4"	200'	30'	TW & TB	4.40
2"	HTN2.00	1 1/2"	3 1/2"	200'	50'	TW & TB	4.60

Halar® is a registered trademark of the Solvay Solexis Corporation.





Teflon

High Temp Stable, Abrasion Resistant, Low Outgassing

TEFLON® (TF) expandable sleeving is ideal in applications where flame, chemical and very high temperature resistance are significant considerations. Our Teflon® sleeving meets current aviation/aerospace specifications.

The high temperature properties of TF make it the ideal choice for aerospace, military and high-tech applications where thermal stability and low outgassing are critical. TF is suitable for plenum applications. TF is braided from 16 mil Teflon perfluoroalkoxy (PFA) polymer monofilament.



- **Plenum Suitable**
- **FAR 25 Approved**
- **Easy to Install**
- **Cut and Abrasion Resistant**
- **Expands up to 150%**
- **Resists Gasoline and Other Chemicals**
- **Temperature Range -94°F to 550°F**
- **Melt Temp. 590°F**

What Makes Teflon® So Special?

Since its accidental discovery in 1938, Teflon has emerged as one of the most useful polymers in existence. Teflon® is inert to virtually all chemicals and is considered the most slippery material on the planet. These properties have made it one of the most valuable and versatile technologies ever invented, contributing to advancements in areas such as aerospace, communications, electronics, industrial processes and architecture.

One of Teflon's most unusual properties was only recently discovered. When strands of PTFE are pulled, they actually get fatter rather than thinner! This makes the polymer incredibly hard without being brittle.



Cabling in passenger area plenums aboard aircraft are a perfect application for Teflon's low outgassing properties.

Nominal Size	Part #	Expansion Range		Standard Spool Put-Ups		Available Colors	Lbs/100'
		Min.	Max.	Bulk Spool	Shop Spool		
1/8"	TFN0.13NT	3/32"	1/4"	1,000'	225'	Natural (NT)	0.50
1/4"	TFN0.25NT	3/16"	3/8"	1,000'	200'	Natural (NT)	0.68
3/8"	TFN0.38NT	1/4"	3/4"	500'	125'	Natural (NT)	2.20
1/2"	TFN0.50NT	3/8"	7/8"	500'	100'	Natural (NT)	2.60
3/4"	TFN0.75NT	5/8"	1 1/4"	250'	75'	Natural (NT)	2.90
1 1/4"	TFN1.25NT	1 1/8"	1 1/2"	200'	50'	Natural (NT)	4.80
1 3/4"	TFN1.75NT	1 3/8"	1 3/4"	200'	50'	Natural (NT)	5.50
2"	TFN2.00NT	1 11/16"	2 1/8"	200'	25'	Natural (NT)	6.40
Overexpanded							
1/2"	TFO0.50NT	3/8"	1"	500'	100'	Natural (NT)	2.60



High temperature resistance allows Teflon sleeving to function in high-temp environments.



FAR-25

Teflon® is a registered trademark of the DuPont Corporation.



800 323-5140
www.techflex.com

Flexo PPS

- **FAR 25 Approved**
- **Ultra Light Weight**
- **Highly Abrasion Resistant**
- **Expands up to 150%**
- **Resists Acids, Bases, Solvents, and Fuels**
- **Temperature Range -94°F to 392°F**
- **Melt Temp. 545°F**

Ultra Lightweight, High-Temp Tolerant and Virtually Impervious to Chemical Degradation

FLEXO PPS expandable sleeving is used in high temperature, flame resistant wire harnesses and cable assemblies. Flexo PPS is an extremely lightweight sleeving, resistant to high temperatures and virtually impervious to solvents. Flexo PPS is ideal for aerospace, telecom and military applications and meets many engineering goals including; chemical resistance, high temperature stability, zero moisture absorption, excellent dimensional stability and ultra-low wear.

Flexo PPS is braided from 8 mil flame resistant PolyPhenylene Sulfide (PPS) monofilament fibers. PPS offers the broadest resistance to chemicals of any advanced engineering plastic. The material resists all known solvents below 392°F and is inert to steam, strong bases, fuels and acids.



A true aerospace material, Flexo PPS is ideal in satellite applications where weight and stability are of primary importance.



Flame resistance, strength and low weight make Flexo PPS sleeving the first choice in high-tech aeronautic design specifications.



Nominal Size	Part #	Expansion Range		Standard Spool Put-Ups		Available Colors	Lbs/100'
		Min.	Max.	Bulk Spool	Shop Spool		
1/8"	RYN0.13	3/32"	1/4"	1,000'	225'	NT & BK	0.21
1/4"	RYN0.25	1/8"	3/8"	1,000'	200'	NT & BK	0.36
1/2"	RYN0.50	1/4"	3/4"	500'	100'	NT & BK	0.59
3/4"	RYN0.75	1/2"	1 1/4"	250'	75'	NT & BK	0.75
1 1/4"	RYN1.25	3/4"	1 3/4"	250'	50'	NT & BK	1.30
1 3/4"	RYN1.75	1 1/4"	2 1/2"	200'	50'	NT & BK	1.60
2"	RYN2.00	1 5/16"	2 3/8"	200'	50'	NT & BK	2.00





Kevlar

Stronger than Steel, Soft & Pliable

KEVLAR® (KV) is a soft, flexible sleeving that's perfect for bundling and protecting vulnerable components from the most extreme environmental conditions. KV is braided from aramid fibers and has all of Kevlar's well-known characteristics of durability, pliability and extraordinary tensile strength. Kevlar fibers are up to 20 times stronger than steel fibers of equal diameter.

KV has excellent thermal stability, permitting long-term, continuous use at temperatures as low as -274°F and as high as 320°F. Short term exposure up to 572°F can be tolerated. KV does not melt or support combustion. KV sleeving provides extreme strength and durability, yet is lightweight and easy to install.

Nominal Size	Part #	Expansion Range		Standard Spool Put-Ups		Available Colors	Lbs/100'
		Min.	Max.	Bulk Spool	Shop Spool		
1/4"	KVN0.25YL	1/8"	5/16"	500'	50'	Yellow (YL)	0.30
1/2"	KVN0.50YL	1/4"	5/8"	250'	50'	Yellow (YL)	0.74
3/4"	KVN0.75YL	1/2"	7/8"	250'	50'	Yellow (YL)	1.44
1"	KVN1.00YL	3/4"	1 1/4"	200'	25'	Yellow (YL)	1.92
1 1/4"	KVN1.25YL	1"	1 5/8"	125'	25'	Yellow (YL)	2.40
1 1/2"	KVN1.50YL	1 1/4"	2"	100'	25'	Yellow (YL)	2.90
2"	KVN2.00YL	1 3/4"	2 1/2"	100'	25'	Yellow (YL)	3.60

- **Up to 20 Times Stronger Than Steel**
- **Will Not Melt, Burn or Support Combustion**
- **Stays Soft, Flexible & Pliable Throughout -274°F to 320°F Operating Temp. Range**



Kevlar Shears
KVS0.00SV
(See pg. 73)

 Kevlar® is a registered trademark of the DuPont Corporation.

Vectran

Vectran

A Unique Combination of Properties for Demanding Applications

VECTRAN® (VE) is a high-performance multifilament yarn spun from liquid crystal polymer. Pound for pound Vectran fiber is five times stronger than steel and ten times stronger than aluminum, which makes it the material of choice in demanding applications where other fibers fail to meet performance requirements.

Our product also demonstrates minimal moisture absorption, outstanding cut and abrasion resistance, high dielectric strength, and melt temperature of 625°F.

Vectran sleeving is used in a wide range of applications, including aerospace, high tech research, industrial protection, marine and medical uses.

Nominal Size	Part #	Wall Thickness	Expansion Range		Standard Spool Put-Ups		Available Colors	Lbs/100'
			Min.	Max.	Bulk Spool	Shop Spool		
1/8"	VEN0.13NT	.025"	7/64"	9/64"	500	100	Natural (NT)	0.36
1/4"	VEN0.25NT	.025"	13/64"	19/64"	500	100	Natural (NT)	0.72



Vectran's molecular structure not only makes it one of the world's strongest materials but vectran is also invisible in MRI systems.

Vectran® is a registered trademark of the Kuraray Co., LTD.

800 323-5140
www.techflex.com



PEEK

Secures performance of sensitive items in challenging environments

Similar to PPS, but with a substantially expanded operating temperature range, PEEK (PolyEtherEther-Ketone) is a high performance advanced polymer with outstanding physical properties. PEEK is inherently flame retardant, with a V-O flammability rating, will withstand continuous use in superheated water or steam up to 500°F, and resists most acids, solvents and bases.

PEEK is FDA approved as a food contact product, resists damage from radiation and will continue to perform in UHV (Ultra High Vacuum) environments. PEEK is extensively used in the aerospace, automotive, teletronic and chemical process industries, and is considered an advanced biomaterial used in medical implants and other biomedical applications. PEEK will withstand thousands of sterilization cycles without damage or degradation.

Flexo PEEK expandable sleeving is tightly braided from 10 mil filaments of pure, unfilled PEEK polymer. The sleeving expands to fit over connectors and splices, and provides a full coverage over wires hoses and cable bundles in advanced engineering applications.



- **High Chemical & Insoluble Resistance in Common Solvents Including Acids, Salts and Oil**
- **Very Light Weight**
- **Excellent Strength in High Temperature & Harsh Environments**
- **Low Outgassing**
- **V-O Flammability Rating**
- **Halogen Free**
- **Non-Corrosive and Non-Conductive**



Nominal Size	Part #	Expansion Range		Standard Spool Put-Ups		Available Colors	Lbs/100'
		Min.	Max.	Bulk Spool	Shop Spool		
1/8"	PKN0.13BK	1/16"	5/16"	1,000'	225'	Black (BK)	0.16
1/4"	PKN0.25BK	7/64"	9/16"	1,000'	200'	Black (BK)	0.19
3/8"	PKN0.38BK	5/32"	5/8"	500'	125'	Black (BK)	0.31
1/2"	PKN0.50BK	3/16"	15/16"	500'	100'	Black (BK)	0.44
5/8"	PKN0.63BK	1/4"	1 1/4"	500'	100'	Black (BK)	0.51
3/4"	PKN0.75BK	3/8"	1 3/8"	250'	75'	Black (BK)	0.64
1"	PKN1.00BK			250'	65'	Black (BK)	0.71
1 1/4"	PKN1.25BK			250'	50'	Black (BK)	0.86
1 1/2"	PKN1.50BK			200'	40'	Black (BK)	1.28
1 3/4"	PKN1.75BK			200'	30'	Black (BK)	1.61
2"	PKN2.00BK			200'	50'	Black (BK)	2.14

PEEK® is a registered trademark of the Victrex Corporation.



Insultherm

- **Resin Saturated, Heavy Weight Braided Fiberglass Won't Burn, Melt or Become Brittle**
- **Minimal Dusting When Cut & Handled**
- **Cut and Abrasion Resistant**
- **Easy to Install - Cuts with Scissors**
- **Resists Gasoline and Engine Chemicals**

Resin Saturated Fiberglass Protects up to 1,200°F

INSULTHERM (FG) is an extremely high temperature resistant sleeve commonly used as thermal protection for wires, cables and hoses that are subjected to continuous and extreme high temperature environments, such as engine manifolds and exhaust systems.

FG is braided from fiberglass yarns and saturated with high temperature resins. FG is tough and durable, maintaining its tight structure under extreme vibration, abrasion, mechanical stress and temperature variations.

FG is available in a wide range of diameters. It installs easily over a variety of applications to either deflect or retain heat in environments up to 1,200°F.

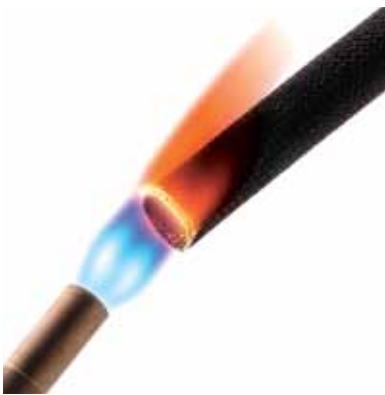

Insultherm resin saturated braided fiberglass sleeving is ideal in areas where fire and extremely high temperatures create a hazard to personnel and equipment.



Nominal Size	Part #	Maximum Diameter	Wall Thickness	Standard Spool Put-Ups		Available Colors	Lbs/100'
				Bulk Spool	Shop Spool		
1/4"	FGN0.25	3/8"	.031"	200'	50'	SV & BK	2.00
3/8"	FGN0.38	5/8"	.043"	200'	50'	SV & BK	3.30
1/2"	FGN0.50	3/4"	.046"	200'	50'	SV & BK	4.80
5/8"	FGN0.63	7/8"	.046"	200'	50'	SV & BK	5.30
3/4"	FGN0.75	1 1/8"	.046"	200'	50'	SV & BK	6.40
7/8"	FGN0.88	1 1/4"	.046"	200'	50'	SV & BK	8.70
1"	FGN1.00	1 5/8"	.057"	100'	25'	SV & BK	10.50
1 1/2"	FGN1.50	2 5/8"	.061"	100'	25'	SV & BK	16.00



Insultherm TF

Heat Treated, Fray-Resistant Fiberglass Sleeving

Techflex INSULTHERM TRU-FIT (FGL) is a braided fiberglass sleeving which has been heat treated and impregnated with an acrylic binder to reduce fraying and dusting, and improve usability and performance. FGL is engineered for applications where temperatures as high as 1,200°F may be encountered.

FGL is used as primary insulation on low voltage applications such as leads in toasters, coffee makers, ranges and other appliances. FGL may also be used as insulation and protection for small heaters and resistors that operate at high temperatures, and to insulate over soldered connections when exposure to solder melt temperatures is possible.

Insultherm Tru-Fit provides a sturdy, long lasting and inexpensive insulation solution. It is flexible and expandable, and can easily be installed over applications with irregular shapes and tight turns. Standard colors are Black and Natural, but other colors are available by special order. Contact your Account Representative for details.

- **Rated to 464°F**
- **For High Temp - Low Voltage Applications**
- **Cut and Abrasion Resistant**
- **UL Recognized: VW-1**
- **Easy to Install - Cuts with Scissors**
- **Excellent Low Temp Flexibility**
- **Resists Most Organic Solvents**

Nominal Size	Diameter	Part #	Wall Thickness	Expansion Range		Standard Spool Put-Ups		Available Colors
				Min.	Max.	Bulk Spool	Shop Spool	
24	0.022"	FGLG.24	.006"	0.020"	0.027"	500'	250'	BK & NT
22	0.027"	FGLG.22	.006"	0.025"	0.032"	500'	250'	BK & NT
20	0.034"	FGLG.20	.006"	0.032"	0.039"	500'	250'	BK & NT
18	0.042"	FGLG.18	.006"	0.040"	0.049"	500'	250'	BK & NT
16	0.053"	FGLG.16	.006"	0.051"	0.061"	500'	250'	BK & NT
14	0.066"	FGLG.14	.006"	0.064"	0.072"	500'	250'	BK & NT
12	0.085"	FGLG.12	.006"	0.081"	0.089"	250'	100'	BK & NT
11	0.095"	FGLG.11	.008"	0.091"	0.101"	250'	100'	BK & NT
10	0.106"	FGLG.10	.008"	0.102"	0.112"	250'	100'	BK & NT
9	0.118"	FGLG.09	.008"	0.114"	0.124"	250'	100'	BK & NT
8	0.133"	FGLG.08	.008"	0.129"	0.141"	250'	100'	BK & NT
7	0.148"	FGLG.07	.008"	0.144"	0.158"	250'	100'	BK & NT
6	0.166"	FGLG.06	.010"	0.162"	0.178"	250'	100'	BK & NT
5	0.186"	FGLG.05	.010"	0.182"	0.198"	250'	100'	BK & NT
4	0.208"	FGLG.04	.010"	0.204"	0.224"	250'	100'	BK & NT
3	0.234"	FGLG.03	.010"	0.229"	0.249"	250'	100'	BK & NT
2	0.263"	FGLG.02	.010"	0.258"	0.278"	250'	100'	BK & NT
1	0.294"	FGLG.01	.010"	0.289"	0.311"	100'	50'	BK & NT
0	0.330"	FGLG.00	.016"	0.325"	0.347"	100'	50'	BK & NT
3/8"	0.375"	FGL0.38	.016"	0.375"	0.399"	100'	50'	BK & NT
7/16"	0.438"	FGL0.44	.016"	0.438"	0.462"	100'	50'	BK & NT
1/2"	0.500"	FGL0.50	.016"	0.500"	0.524"	100'	50'	BK & NT
5/8"	0.625"	FGL0.63	.016"	0.625"	0.655"	100'	50'	BK & NT
3/4"	0.750"	FGL0.75	.016"	0.750"	0.786"	100'	50'	BK & NT



Protect component wiring leads from heat and abrasion with Insultherm Tru-Fit for an attractive and permanent finish.



Insultherm

- **Continuous Filament E-Type Glass**
- **Resists Abrasion, Vibration, and Mechanical Stress**
- **Easy to Install - Cuts With Scissors**
- **Stays Flexible in Low Temperatures**



Braided Fiberglass Protects up to 1,200°F

INSULTHERM ULTRAFLEXX (FH) fiberglass sleeving is ideal for the protection of wires and hoses exposed to the heat generated from high performance engine and exhaust components.

The heat treated sleeving cuts with scissors and is highly flexible.

Ultraflexx expands slightly, allowing it to slide easily over wires and follow curves and contours without binding.

Nominal Size	Part #	Wall Thickness	Expansion Range		Standard Spool Put-Ups		Available Colors	Lbs/100'
			Min.	Max.	Bulk Spool	Shop Spool		
1/4"	FHN0.25NT	.010"	1/4"	5/16"	250'	100'	Natural (NT)	1.00
3/8"	FHN0.38NT	.012"	3/8"	1/2"	250'	100'	Natural (NT)	1.20
1/2"	FHN0.50NT	.013"	1/2"	5/8"	100'	50'	Natural (NT)	1.60
5/8"	FHN0.63NT	.024"	5/8"	3/4"	100'	50'	Natural (NT)	3.00
3/4"	FHN0.75NT	.024"	3/4"	7/8"	100'	50'	Natural (NT)	3.80
1"	FHN1.00NT	.024"	1"	1 1/4"	100'	50'	Natural (NT)	4.30



Insultherm



Insultherm Ultraflexx Pro expands up to 50% for easy installation

Heavy Wall Fiberglass Protects up to 1,200°F

The heavy wall construction, large available diameters and high expandability of ULTRAFLEXX PRO (FH) provides a high level of protection and ease of installation when used to insulate pipes and hoses subject to abrasion and vibration. Ultraflexx Pro cuts easily with scissors, and special heat treated construction minimizes fraying and dusting during assembly. Increased wall thickness adds value to insulation.

Nominal Size	Part #	Wall Thickness	Expansion Range		Standard Spool Put-Ups		Available Colors	Lbs/100'
			Min.	Max.	Bulk Spool	Shop Spool		
1/2"	FHH0.50NT	.025"	3/8"	5/8"	100'	50'	Natural (NT)	3.50
3/4"	FHH0.75NT	.040"	5/8"	1 5/32"	100'	50'	Natural (NT)	8.00
1"	FHH1.00NT	.032"	7/8"	1 3/8"	50'	25'	Natural (NT)	7.00
1 1/4"	FHH1.25NT	.035"	1"	1 3/4"	50'	25'	Natural (NT)	10.50
1 1/2"	FHH1.50NT	.035"	1 1/8"	2 1/8"	50'	25'	Natural (NT)	10.00





Insultherm Sleeves

Double Wall Fiberglass Sleeves Protect Wires & Spark Plug Boots to 1,200°F

For decades, Techflex's Insultherm braided fiberglass sleeving has been the first choice among automotive professionals and enthusiasts alike for many of their thermal protection applications.

These innovative sleeves offer the same high temperature protection in an easy slip on sleeve that will extend the life of expensive spark plug wires by protecting them where they need it most... at the boot. Just slip these 3/4" diameter double thickness (triple thick at the sewn end) sleeves over any spark plug cable and boot (even right angle boots) to protect them from engine temperatures up to 1,200°F. Once installed, the sleeves require no clearance from hot surfaces, and can even rest directly on hot exhaust headers without affecting performance.

Insultherm Spark Plug Boot Sleeves are completely non-conductive, resist all engine chemicals, will not support combustion, and provide an easy, economical solution to the challenge of wire protection in the cramped, high temperature environment of any high performance engine compartment.

- **Economical, Long Lasting Protection**
- **Easy, Slip On Installation**
- **Protects up to 1,200°F**
- **Halogen Free**
- **Resists Gasoline and Engine Chemicals**



Insultherm Spark Plug Boot Sleeves are available in retail packaging as part of Techflex's "Double Yellow" performance products line. Contact your Account Representative for standard or custom retail packaging.



Insultherm Spark Plug Boot Sleeves can rest directly on hot headers and other engine components without burning, melting or becoming brittle.

Nominal Size	Part #	Diameter	Wall Thickness	Bulk Box	Available Colors
No Ring-Easy Install					
4 1/2"	FBN0.75	3/4"	.085"	144	NT in-stock color; all other available by special order only
7 1/2"	FCN0.75	3/4"	.085"	144	
12"	FDN0.75	3/4"	.085"	144	
With Ring					
7 1/2"	FCU0.75	3/4"	.085"	144	NT, BL, BK, RD



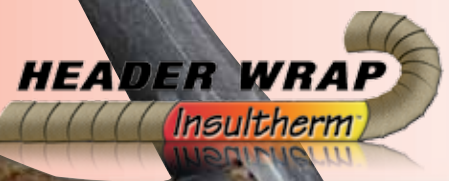

Header Wrap

- High Temp. Resistant
- Easy to Install
- Resists Gasoline and Engine Chemicals
- Increases Horsepower and Improves Fuel Mileage
- Cut & Abrasion Resistant
- Halogen Free

Vermiculite Coated Fiberglass Wrap Withstands Heat up to 1,200°F

HEADER WRAP INSULTHERM™ (HF) is extremely high temperature resistant. Commonly used for automotive and high performance headers and exhausts.

Manufactured from texturized fiberglass yarns and woven into a strong and flexible wrap with vermiculite coating.



Remember when it comes to exhaust wrap, overlapping 1/4" is perfect as this allows just enough heat out to ensure performance without damaging your exhaust.



Wall Thickness	Widths	Part #	Maximum Continuous Temperature	Standard Spool Put-Ups		Available Colors	Lbs/100'
				Bulk Spool	Shop Spool		
1/16"	1"	HFN1.00	1,000°F	100'	50'	NT & BK	1.50
1/16"	2"	HFN2.00		100'	50'		3.05

CUSTOM CONFIGURATIONS

Thickness Available: 1/16", 1/8" Widths Available: 1/2" – 6"
Contact us for custom product options.

HEADER WRAP and HEADER WRAP SI - Reduces under-hood temperatures up to 70%, increases horsepower and fuel efficiency. Techflex Header Wrap works by holding heat within the header, which creates a better exhaust flow. This allows easy removal of spent gasses and creates more airflow to the engine.

Header Wrap SI



- High Temp. Resistant
- Easy to Install
- Resists Gasoline and Engine Chemicals
- Cut and Abrasion Resistant

Silica Wrap Withstands Continuous Heat up to 2,000°F

HEADER WRAP SI INSULTHERM™ (HS) is made from texturized amorphous silica filament yarn woven into a strong and flexible form. Because the yarn is texturized into a bulky form it provides excellent insulating values.

Header Wrap SI is not made from leached fiberglass, resulting in a much more wear resistant finished product.



Wall Thickness	Widths	Part #	Maximum Continuous Temperature	Standard Spool Put-Ups		Available Colors	Lbs/100'
				Bulk Spool	Shop Spool		
1/16"	1"	HSN1.00NT	2,000°F	100'	50'	Natural (NT)	1.50
1/16"	2"	HSN2.00NT		100'	50'		3.05

CUSTOM CONFIGURATIONS

Thickness Available: 1/16", 1/8" Widths Available: 1" – 4"
Contact us for custom product options.

Volcano Wrap

Woven Volcanic Rock Tape Withstands Heat up to 1,500°F

VOLCANO WRAP (VW) is made from continuous filament basalt fiber and is engineered for protection from temperatures 1,500°F. When wrapped around exhaust pipes, the unique construction creates attractive and durable finished product.

Volcano Wrap is 25% stronger and provides a 300°F increase in temperature protection over fiberglass wrap. The product is very rugged, and will not exhibit any vibration damage over long periods of use.

The volcanic rock fiber wrap is easy to install and will provide years of protection and good looks.

- **High Temperature Resistance**
- **Easy to Install**
- **Resists Gasoline and Engine Chemicals**
- **Great Appearance**



Volcano Wrap helps redirect the heat every race or every day in production, keeping engine areas cooler and performance results better.



Wall Thickness	Widths	Part #	Standard Spool Put-Ups			Available Colors	Lbs/100'
			Bulk Spool 1	Bulk Spool 2	Bulk Spool 3		
1/16"	1"	VWN1.00BA	100'	50'	25'	Basalt (BA)	1.70
1/16"	2"	VWN2.00BA	100'	50'	25'	Basalt (BA)	3.20



Silica Sleeve

- **60 Mil Wall Thickness Provides Enhanced Thermal Insulation**
- **High Temperature Resistance**
- **Easy to Install**
- **Resists Gasoline and Engine Chemicals**
- **Cut and Abrasion Resistant**

Easy Slip On Installation ; Protects up to 1,800°F

Densely woven Silica Sleeve (SL) is ideal for protection of delicate components and personnel from exposure to high temperature exhausts and pipes.

Silica Sleeve is braided into a strong and flexible sleeve from silica yarns. The thick 60 mil walls of this sleeving provide enhanced thermal protection up to 1,800°F.

This product cuts easily with scissors or shears and expands to allow easy installation over water cooling hoses, hydraulic hoses, and electrical cables. Also provides great insulation for exhaust systems.



Techflex Silica Sleeve can handle the temperature better than any other flexible sleeving.



Nominal Size	Wall Thickness	Part #	Expansion Range		Standard Spool Put-Ups		Available Colors	Lbs/100'
			Min.	Max.	Bulk Spool	Shop Spool		
1/4"	.060"	SLN0.25NT	1/4"	1/2"	100	50	Natural (NT)	2.60
1/2"	.060"	SLN0.50NT	1/2"	5/8"	100	50	Natural (NT)	5.00
1"	.060"	SLN1.00NT	3/4"	1 5/32"	100	50	Natural (NT)	6.10
1 1/2"	.060"	SLN1.50NT	1"	1 1/2"	100	50	Natural (NT)	10.00
2"	.060"	SLN2.00NT	1 1/4"	2 3/16"	100	25	Natural (NT)	9.00
3"	.060"	SLN3.00NT	2 1/2"	3 1/2"	100	25	Natural (NT)	11.90
4"	.060"	SLN4.00NT	3 1/2"	4 1/2"	100	25	Natural (NT)	14.80
6"	.060"	SLN6.00NT	5 1/2"	6 1/2"	100	25	Natural (NT)	17.70



T6 ThermaShield

Flexible Thermal Reflective Wrap Deflects Radiant Heat up to 1,400°F

One of the most popular items in the ThermaShield line of aluminized fiberglass products, T6, is designed for ease of installation when component disassembly isn't practical. Just wrap the pre-formed, split flexible tube around any component and seal the sides with the high temperature adhesive strip to provide protection from hot pipes and engine components.

The highly reflective aluminized exterior, combined with the insulating fiberglass interior, protects delicate wire bundles, cables and lines from damage caused by nearby exhaust pipes, headers or other heat generating components.

- Heat Reflective Aluminum Laminated Fiberglass
- Self Wrap and Seal Overlap with High Temperature Adhesive Strip
- Reflects Radiant Heat
- Resists Gasoline and Engine Chemicals
- Cut and Abrasion Resistant
- Cuts Cleanly with Scissors
- Halogen Free

After long term exposure to extreme temp. (1,400°F) with the distance of 3/8" from the source of heat, T6 ThermaShield remains flexible and resilient with no delaminating or breaking of the adhesive.

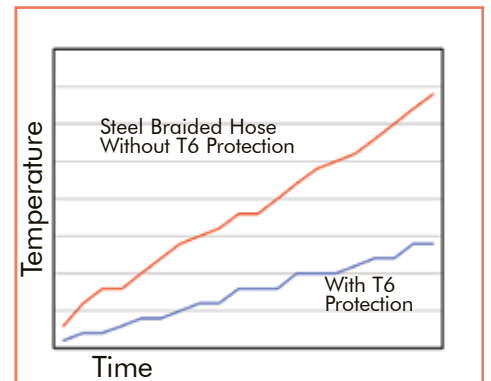
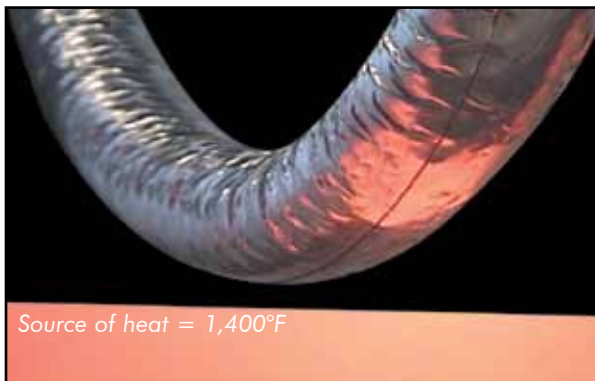

T6 can reduce the heat transmission from hot pipes or engine components into hoses or harnesses by up to 50% or more.

Nominal Size	Wall Thickness ±0.007"	Part #	4' Pcs. Put-Ups				Available Colors	Lbs/10Pcs.
			Bulk Box	Box 8x8	Box 6x6	Box 4x4		
1/4"	.042"	T6F0.25SV	250	140	100	50	Silver (SV)	1.0
3/8"	.042"	T6F0.38SV	250	90	50	30	Silver (SV)	1.5
1/2"	.042"	T6F0.50SV	250	70	40	25	Silver (SV)	2.0
5/8"	.042"	T6F0.63SV	150	60	35	20	Silver (SV)	2.5
3/4"	.042"	T6F0.75SV	125	50	30	15	Silver (SV)	3.0
1"	.042"	T6F1.00SV	70	30	20	9	Silver (SV)	3.5
1 1/4"	.042"	T6F1.25SV	63	20	10	6	Silver (SV)	4.5
1 1/2"	.042"	T6F1.50SV	40	15	8	4	Silver (SV)	5.0
2"	.042"	T6F2.00SV	24	8	4	2	Silver (SV)	6.0



T6 is shipped in pre-cut 4' lengths

ThermaShield

Reflective Aluminized Surface Bonded to Insulating Fiberglass in 4 Styles

TUBE

CONVOLUTED

ThermaShield creates a thermal buffer between your wires, hoses and cables and the high temperature environments surrounding them.

ThermaShield is engineered by laminating an aluminized metallic heat shield to a layer of strong, tightly braided fiberglass insulation. This system provides superior protection from radiant heat by reflecting it away from sensitive electronics, wiring and hoses.

The four styles of ThermaShield; Tube, Convoluted, Wrap and Flat provide a full range of solutions for virtually any application. The Wrap and Flat products use a very aggressive, high temperature adhesive that eliminates the need for high-temp mylar tape or other adhesive.

ThermaShield products will endure temperatures up to 1,200°F without delaminating, turning brittle or suffering adhesive failure.

They are ideal in any situation where protection from radiant heat is a primary concern.

ThermaShield helps keep high performance engines running efficiently.



THERMA SHIELD TUBE

Nominal Size	Part #	Wall Thickness ±0.006"	Standard Spool Put-Ups		Available Colors	Lbs/100'
			Bulk Spool	Shop Spool		
1/2"	TTN0.50SV	.025"	250'	100'	Silver (SV)	2.55
5/8"	TTN0.63SV	.025"	250'	100'	Silver (SV)	3.00
3/4"	TTN0.75SV	.025"	250'	100'	Silver (SV)	3.45
7/8"	TTN0.88SV	.025"	250'	100'	Silver (SV)	4.10
1"	TTN1.00SV	.025"	250'	100'	Silver (SV)	4.50
1 1/4"	TTN1.25SV	.025"	250'	100'	Silver (SV)	5.40
1 1/2"	TTN1.50SV	.025"	250'	100'	Silver (SV)	6.20
1 3/4"	TTN1.75SV	.025"	100'	50'	Silver (SV)	7.40
2"	TTN2.00SV	.025"	100'	50'	Silver (SV)	8.70
2 1/2"	TTN2.50SV	.025"	100'	50'	Silver (SV)	10.10
3"	TTN3.00SV	.025"	100'	50'	Silver (SV)	19.00



THERMA SHIELD

ThermaShield

WRAP

FLAT



THERMA SHIELD CONVOLUTED

Nominal Size	Part #	Wall Thickness ±0.005"	4' Pcs. Put-Ups				Available Colors	Lbs/10Pcs.
			Bulk Box	Box 8x8	Box 6x6	Box 4x4		
1/2"	TCN0.50SV	.045"	250	70	40	25	Silver (SV)	1.2
5/8"	TCN0.63SV	.045"	150	60	35	20	Silver (SV)	1.5
3/4"	TCN0.75SV	.045"	125	50	30	15	Silver (SV)	1.8
1"	TCN1.00SV	.045"	88	30	20	9	Silver (SV)	2.1
1 1/4"	TCN1.25SV	.045"	63	20	10	6	Silver (SV)	2.3

- Cuts Easily with Scissors
- Reflects Radiant Heat
- Insulates Delicate Wires & Components
- Resists Gasoline and Engine Chemicals

THERMA SHIELD WRAP

Nominal Size	Part #	Sheet Width	Wall Thickness ±0.008"	Standard Spool Put-Ups		Available Colors	Lbs/100'
				Bulk Spool	Shop Spool		
1/2"	TWN0.50SV	1 13/16"	.025"	200'	100'	Silver (SV)	2.60
3/4"	TWN0.75SV	2 1/2"	.025"	200'	100'	Silver (SV)	4.00
1"	TWN1.00SV	3 3/8"	.025"	200'	100'	Silver (SV)	5.10
1 1/4"	TWN1.25SV	4 1/4"	.025"	200'	100'	Silver (SV)	5.70
1 1/2"	TWN1.50SV	5"	.025"	200'	100'	Silver (SV)	6.50
1 3/4"	TWN1.75SV	5 13/16"	.025"	100'	50'	Silver (SV)	7.40
2"	TWN2.00SV	6 11/16"	.025"	100'	50'	Silver (SV)	8.40
2 1/4"	TWN2.25SV	7 3/8"	.025"	100'	50'	Silver (SV)	9.50



ThermaShield Flat conforms and adheres to irregular shapes.

THERMA SHIELD FLAT

Nominal Size	Part #	Wall Thickness ±0.006"	Standard Spool Put-Ups		Available Colors	Lbs/100'
			Bulk Spool	Shop Spool		
1"	TSN1.00SV	.025"	200'	100'	Silver (SV)	1.60
1 1/2"	TSN1.50SV	.025"	200'	100'	Silver (SV)	2.00
2"	TSN2.00SV	.025"	200'	100'	Silver (SV)	2.75
3"	TSN3.00SV	.025"	200'	100'	Silver (SV)	4.30
4"	TSN4.00SV	.025"	200'	100'	Silver (SV)	5.60
5"	TSN5.00SV	.025"	200'	100'	Silver (SV)	7.60
6"	TSN6.00SV	.025"	100'	50'	Silver (SV)	9.20
7"	TSN7.00SV	.025"	100'	50'	Silver (SV)	10.90
8"	TSN8.00SV	.025"	100'	50'	Silver (SV)	12.70



Techflex ThermaShield and a competitor's similar product were placed in the same electrical test oven for one hour at 626°F (330°C). Note the burning and delamination of the fiberglass interior of the Brand "X" product. Even the metallic shroud suffered a degree of burning and brittleness that did not occur on the ThermaShield sample.



Nomex

- **Soft, Pliable & Strong**
- **Cut and Abrasion Resistant**
- **Protects to 662°F**
- **Halogen Free**
- **Resists Gasoline and Engine Chemicals**
- **Cut Easily with Scissors**

Soft, Pliable Flame Protection to 662°F

Woven NOMEX (NX) clothing and protective gear has been used for years by race car drivers, municipal fire departments and oil rig personnel to provide that extra level of comfort and protection from the dangers that come with working in and around intense flame and heat. Our NX Nomex sleeving will do the same for your wires, hoses and cables.

NX will protect your application in temperatures up to 662°F. It is unaffected by short term exposure to most acids, bases, solvents and common engineering chemicals. Despite the soft touch and smooth appearance associated with woven aramid fibers, NX is incredibly strong, with a tensile strength of 90,000 psi.

The densely braided sleeving provides full coverage and protection on even the most exposed applications.

NX sleeving cuts easily with regular scissors and the smooth surface eases installation even over long wire runs.



**Proven in the air...
...Proven on the ground**



Nominal Size	Part #	Expansion Range		Standard Spool Put-Ups		Available Colors	Lbs/100'
		Min.	Max.	Bulk Spool	Shop Spool		
1/8"	NXN0.13	1/16"	1/4"	100'	25'	GN & NT	0.12
1/4"	NXN0.25	1/8"	5/16"	100'	25'	GN & NT	0.50
5/16"	NXN0.31	7/32"	7/16"	100'	25'	GN & NT	0.60
3/8"	NXN0.38	1/4"	1/2"	100'	25'	GN & NT	0.67
1/2"	NXN0.50	5/16"	5/8"	100'	25'	GN & NT	0.91
5/8"	NXN0.63	7/16"	7/8"	100'	25'	GN & NT	1.10
3/4"	NXN0.75	9/16"	1"	100'	25'	GN & NT	1.34
1"	NXN1.00	3/4"	1 1/8"	100'	25'	GN & NT	2.42
1 1/4"	NXN1.25	1"	1 1/2"	100'	25'	GN & NT	3.49
1 1/2"	NXN1.50	1 1/4"	1 3/4"	100'	25'	GN & NT	4.03
1 3/4"	NXN1.75	1 1/2"	2"	100'	25'	GN & NT	4.76

Nomex® is a registered trademark of the DuPont Corporation.

800 323-5140
www.techflex.com





**EXTREME
TEMPERATURE**

WeldWrap

Protects Vulnerable Welding Hoses from Catastrophic Failure

Techflex WeldWrap (WW) is braided from fiberglass yarns with high temperature coating and hook and loop closure. Commonly used for protecting welding hoses from molten splatter and abrasion from moving and dragging. This product will withstand continuous exposure to temperatures of 400°F, and intermittent exposure to temperatures of 750°F.

The heavy duty hook and loop closure ensures a tight seal and allows WeldWrap to be installed easily over existing assemblies. WeldWrap also provides a high level of abrasion and penetration protection to increase the useful life of any hoses exposed to rough or abrasive surfaces.

- **Easy to Install**
- **Resists Damage from UV, Gasoline, and Engine Chemicals**
- **Extreme Cut and Abrasion Resistance**
- **Weld Splatter, Hot Slag, and Welding Spark Protection**



WeldWrap bundles and protects hoses on welding robots and static welding stations.

Nominal Size	Part #	Wall Thickness	Velcro Width	Standard Spool Put-Ups		Available Colors	Lbs/100'
				Bulk Spool	Shop Spool		
1"	WWN1.00BK	.04"	0.84"	150'	50'	Black (BK)	8.4
1 1/2"	WWN1.50BK	.04"	0.84"	150'	50'	Black (BK)	11.0
2"	WWN2.00BK	.04"	1.55"	150'	50'	Black (BK)	13.8
2 3/8"	WWN2.38BK	.04"	1.55"	150'	50'	Black (BK)	14.8
2 3/4"	WWN2.75BK	.04"	1.55"	150'	50'	Black (BK)	16.4
3"	WWN3.00BK	.04"	1.55"	150'	50'	Black (BK)	18.4
3 1/4"	WWN3.25BK	.04"	1.55"	150'	50'	Black (BK)	19.2
3 1/2"	WWN3.50BK	.04"	1.55"	150'	50'	Black (BK)	20.4
4"	WWN4.00BK	.04"	1.55"	150'	50'	Black (BK)	21.7



Strong Para Aramid stitching provides long lasting support for the hook and loop.

800 323-5140
www.techflex.com



FireFlex

- **Stable to 500°F**
- **Cut and Abrasion Resistant**
- **Halogen Free**
- **Resists Gasoline and Engine Chemicals**

Silicone Jacketed Fiberglass Resists Heat, Abrasion & Moisture



Techflex silicone jacketed fiberglass is tested under pressure to destruction to insure reliable fire protection for your fuel and hydraulic lines.



Fuel lines in race cars are especially vulnerable to high engine temperatures. FI can help maintain proper fuel temperature.



Silicone jacketed fiberglass sleeving is the choice of professionals in racing and other industries where protection from constant temperatures approaching 500°F is mandatory.

FireFlex fiberglass/silicone sleeving is engineered to protect hoses, cables and wire harnesses from damage due to exposure to extreme heat, open flame, molten splash and welding sparks. The thick, high temperature fiberglass sleeve is jacketed with a non-permeable, heavy silicone coating that is flexible enough to follow tight radius curves, resists all automotive chemicals and solvents, and provides a substantial level of abrasion and puncture protection.

FireFlex is completely non-conductive, will not melt, delaminate, become brittle or support combustion under normal conditions, and provides a professional level solution to thermal protection needs in any application.



Nominal Size	Part #	Maximum Diameter	Wall Thickness ±0.010"	Standard Spool Put-Ups		Available Colors	Lbs/100'
				Bulk Spool	Shop Spool		
1/4"	FIN0.25	N/A	.072"	100'	50'	BK & RD	4.80
3/8"	FIN0.38	N/A	.072"	100'	50'	BK & RD	6.30
1/2"	FIN0.50	N/A	.072"	100'	50'	BK & RD	7.40
5/8"	FIN0.63	N/A	.072"	100'	50'	BK & RD	8.80
3/4"	FIN0.75	N/A	.072"	50'	25'	BK & RD	9.80
7/8"	FIN0.88	N/A	.072"	50'	25'	BK & RD	10.10
1"	FIN1.00	N/A	.072"	50'	25'	BK & RD	13.50
1 1/4"	FIN1.25	N/A	.072"	50'	25'	BK & RD	14.00
1 1/2"	FIN1.50	N/A	.072"	50'	25'	BK & RD	14.70
1 3/4"	FIN1.75	N/A	.072"	50'	25'	BK & RD	16.30
2"	FIN2.00	N/A	.072"	50'	25'	BK & RD	20.50
2 1/4"	FIN2.25	N/A	.072"	50'	25'	BK & RD	22.90
2 3/8"	FIN2.38	N/A	.072"	50'	25'	BK & RD	26.90
2 1/2"	FIN2.50	N/A	.072"	50'	25'	BK & RD	28.30
2 3/4"	FIN2.75	N/A	.072"	50'	25'	BK & RD	30.10
2 7/8"	FIN2.88	N/A	.072"	50'	25'	BK & RD	32.00
3"	FIN3.00	N/A	.072"	50'	25'	BK & RD	33.40
3 1/2"	FIN3.50	N/A	.072"	25'	-	BK & RD	37.20
4"	FIN4.00	N/A	.072"	25'	-	BK & RD	40.10





FireFlex Aero

High Temperature Sleeve AS1072 Aerospace Grade

FireFlex Aero (FI) is engineered from a dense braided fiberglass sleeve and a thick coating of self-extinguishing high temperature silicone rubber that withstands 500°F continuous exposure, and molten splash up to 2,000°F.

Almost every aviation engine - turbine, turboprop or piston; civilian and military - uses FireFlex Aero to protect critical hoses and wiring in the event of an engine compartment fire. FireFlex Aero meets the specification of AS1072, allowing qualified hose assemblies to pass the fire resistance testing specification of AS1055D.

FireFlex Aero is highly resistant to hydraulic fluids, lubricating oils, and fuels. The dense braided fiberglass interior insulates against energy loss in piping and hosing, while the high density silicone coating protects personnel from accidental injury.

- **Extra Thick Braid & Heavy Coating for Critical Aerospace Applications**



Used on both military and commercial aircraft to defend hose systems from fire and thermal events.



Nominal Size	Part #	Maximum Diameter	Wall Thickness	Standard Spool Put-Ups		Available Colors	Lbs/100'
				Bulk Spool	Shop Spool		
1/4"	FIA0.25	N/A	.115"	100'	50'	BK & RD	8.04
3/8"	FIA0.38	N/A	.115"	100'	50'	BK & RD	9.96
7/16"	FIA0.44	N/A	.115"	100'	50'	BK & RD	12.96
1/2"	FIA0.50	N/A	.115"	100'	50'	BK & RD	14.04
5/8"	FIA0.63	N/A	.115"	100'	50'	BK & RD	20.04
3/4"	FIA0.75	N/A	.115"	50'	25'	BK & RD	21.96
7/8"	FIA0.88	N/A	.115"	50'	25'	BK & RD	26.04
1"	FIA1.00	N/A	.115"	50'	25'	BK & RD	33.00
1 1/8"	FIA1.13	N/A	.115"	50'	25'	BK & RD	35.04
1 1/4"	FIA1.25	N/A	.115"	50'	25'	BK & RD	36.96
1 3/8"	FIA1.38	N/A	.115"	50'	25'	BK & RD	44.04
1 1/2"	FIA1.50	N/A	.115"	50'	25'	BK & RD	48.00
1 5/8"	FIA1.63	N/A	.115"	50'	25'	BK & RD	38.04
1 3/4"	FIA1.75	N/A	.115"	50'	25'	BK & RD	42.00
1 7/8"	FIA1.88	N/A	.115"	50'	25'	BK & RD	44.04
2"	FIA2.00	N/A	.115"	50'	25'	BK & RD	48.00
2 1/4"	FIA2.25	N/A	.115"	50'	25'	BK & RD	55.00
2 1/2"	FIA2.50	N/A	.115"	50'	25'	BK & RD	65.04
2 3/4"	FIA2.75	N/A	.115"	50'	25'	BK & RD	76.20
3"	FIA3.00	N/A	.115"	50'	25'	BK & RD	87.00



Studio Key Sleeve

- **Durable and Reusable Design**
- **Works Well in Both Film and Video Shoots**
- **Patent Pending**
- **Covers Wires and Set Pieces**

Keyable Sleeve For Special Effects Professionals

Blue/green screen was originally invented as a film technique to separate the actors and composite them over another background. The reason both green and blue are used because they are the least prominent colors in our skin tone. The goal in using a green or a blue screen is to isolate the subject.

Following the same concept, Techflex engineers have designed STUDIO KEY SLEEVE (SK), a reversible, bright blue/green sleeving, which is perfect cover-up for wires on your set. During film editing, you can easily key-out the green and blue colors, so you will be left with just your subject without any background or wires hanging around and set pieces.

Studio Key Sleeve is made of durable, two sided vinyl, with blue on one side and green on other, and it has hook and loop for quick and easy installation. Our sleeving is thick enough not to let the light pass through it, and also protects your cables against unwanted moisture.



Whether your studio is set up for green or blue, reversible Key Sleeve has you covered.



Studio Key Sleeve works great for temporarily covering valuable light booms and stationary poles.



Nominal Size	Part #	Wall Thickness	Hook & Loop	Standard Spool Put-Ups		Available Colors	Lbs/10'
				Spool Length			
2"	SKN2.00BG	.048"	1"	10'		Blue/Green (BG)	2.25

*Contact your Account Representative for additional sizes.

Flexo Mounting System

The Ultimate Termination Solution For Flexo Sleeving

Our new patented Flexo Mounting System (FMS) has been created to attractively terminate applications with a secure mountable end. This new Mounting System is engineered to work great with Flexo PET 1 1/2" & 1 3/4", (pg. 4) and with Flexo Clean Cut 1 1/2" (pg. 7).

The installer friendly part clamps securely onto the sleeve without attaching to your wiring for ideal strain relief. The two piece construction removes any limitations in size created by large connectors and preserves the sleeving expandability.

Automotive grade glass filled nylon construction is suitable for a variety of applications.

At the heart of the FMS is the Snap Ring Collar. When used in conjunction with the pressure ring permanently holds the sleeve.



When used in conjunction with the Techflex wall plate, the FMS creates a lasting terminated assembly.



Part #	Description	Available Colors	Lbs/Pkg.
FMS1.50FL	Packaging of a Single Flange	Black (BK)	0.03
FMS1.50FL5	Packaging of 5 Pc. Flange	Black (BK)	0.15
FMP1.50PLATE	Wall Plate only (includes 2 screws)	Black (BK), Almond (BE) & White (WH)	0.09
FMS1.50FK	Finishing Pack: 1 Flange & 1 Wall Plate	Black (BK), *Almond (BE) & *White (WH) (*Plate only)	0.12

Easy Field Installation



Universal Screw Mount

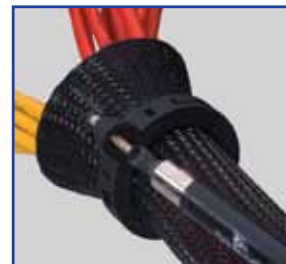

Easy Clip, No Special Tool Required



Fits In Single Gang Wall Box



Super Strong Strain Relief For Your Wires



800 323-5140
www.techflex.com



Dura-Race

- **Tightly Woven Ballistic Nylon Construction**
- **Heavy Duty Hook Closure for Carpet Installation**
- **Repels Liquids**
- **Resists and Prevents Damage from UV, Abrasion, & Chemicals**
- **Custom Lengths Available**

Abrasion Protection for High-Traffic Carpeting with Easy On, Easy Off Hook Closure

DURA RACE (DR) is the solution for hiding and protecting wires that are exposed on carpeted areas. Dura Race is braided from a tightly woven ballistic Nylon.

With industrial strength hook closure, this covering will adhere to most industrial and high traffic carpeting, making it easy to lay over wires, cables or hoses keeping them protected from abrasion. Dura Race tightly holds the application close to the carpeting, avoiding trips or falls on free lying wires.

DR provides greater abrasion resistance and water repellency compared to other Nylon® sleeves.

Best Applied to:



Loop Pile



Cut & Loop Pile



Patterned Loop Pile

Not Recommended for:



Cut Pile

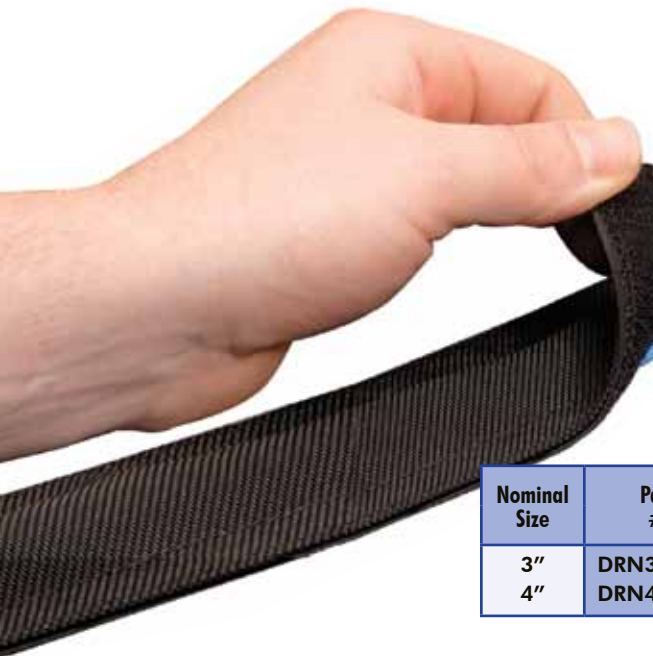

Dura Race is a great safety enhancement for offices and other cabled environments.

Nominal Size	Part #	Wall Thickness	Standard Spool Put-Ups		Available Colors	Lbs/100'
			Bulk Spool	Shop Spool		
3"	DRN3.00BK	.012"	100'	50'	Black (BK)	4.29
4"	DRN4.00BK	.012"	100'	50'	Black (BK)	5.26



Slip Resistant Expandable Braided Sleeving

NON-SKID**Non-Skid**

Increased Friction on Smooth Surfaces Minimizes Slipping & Accidents

FLEXO NON-SKID (NS) is a unique combination of our standard PET material braided together with high-friction polymer filaments.

NS is engineered primarily for wire and cable management on smooth floor, high traffic environments such as broadcast studios where someone might inadvertently step on a cable snake and slip.

As long as there's no excessive pressure on the cables protected with NS, the entire snake glides easily and quietly along the floor. When local pressure is applied, such as when someone steps on the cable, the high friction material comes in contact with the floor and reduces the possibility of the cable sliding out from underfoot.

NS is substantially less "slippery" than our regular PET, yet provides the same level of flexibility and protection from cable wear and abrasion.



- **Manages & Protects Cable Bundles**
- **Increases Safety in Foot Traffic Areas**
- **Economical and Easy to Install**
- **Cut and Abrasion Resistant**
- **Expands up to 150%**



NonSkid is ideal for smooth floor areas such as photo, film and TV studios where cable snakes, high foot traffic and low light combine to create a slipping hazard.

Nominal Size	Part #	Expansion Range		Standard Spool Put-Up		Available Colors	Lbs/100'
		Min.	Max.	Bulk Spool	Shop Spool		
1/4"	NSN0.25	1/8"	7/16"	1,000'	200'	NY & BK	0.44
1/2"	NSN0.50	1/4"	3/4"	500'	100'	NY & BK	0.89
5/8"	NSN0.63	3/8"	1"	500'	100'	NY, BK & SS	1.04
3/4"	NSN0.75	1/2"	1 1/4"	250'	70'	NY & BK	1.25
1 1/4"	NSN1.25	3/4"	1 3/4"	200'	50'	NY, BK & SS	1.96
1 1/2"	NSN1.50	1"	2 1/2"	200'	40'	NY & BK	2.25
2"	NSN2.00	1 1/2"	3 1/2"	200'	50'	NY & BK	2.75



800 323-5140
www.techflex.com



Nylon Mono

- **Economical and Easy to Install**
- **Braided From 12 Mil Nylon 6-6 Polyamide Monofilament Yarns**
- **Cut and Abrasion Resistant**
- **Expands up to 150%**
- **Halogen Free**
- **Resists Gasoline and Engine Chemicals**

Reliability Recognized Around the World

NYLON MONO (NY) is commonly used in the automotive industry to protect hoses and wire harnesses from excessive wear. NY's tough characteristics can increase hose life up to 300%. This lengthened life span is recognized in terms of reduced maintenance, a professional, attractive and durable appearance and greater customer satisfaction. With the additional protection that NY provides, it pays for itself throughout the life of your product.

NY is braided from 12 mil Nylon 6-6 Polyamide monofilament. The tight braid construction covers fully and provides excellent surface abrasion resistance for assemblies exposed to excessive wear. The smooth nylon fibers and tight construction also reduce abrasion damage caused by hoses and harnesses rubbing against the inside wall of the sleeving.

NY resists all common automotive chemicals. It won't rot or retain moisture.



NY's qualities of toughness and ease of installation make it the choice of auto manufacturers for protecting and managing cables and wire harnesses.



Nominal Size	Part #	Expansion Range		Standard Spool Put-Ups		Available Colors	Lbs/100'
		Min.	Max.	Bulk Spool	Shop Spool		
1/8"	NYN0.13BK	3/32"	1/4"	1,000'	225'	Black (BK)	0.22
1/4"	NYN0.25BK	1/8"	3/8"	1,000'	200'	Black (BK)	0.31
3/8"	NYN0.38BK	1/4"	7/16"	500'	125'	Black (BK)	0.72
1/2"	NYN0.50BK	3/8"	3/4"	500'	100'	Black (BK)	1.03
5/8"	NYN0.63BK	7/16"	1"	500'	100'	Black (BK)	1.12
3/4"	NYN0.75BK	1/2"	1 1/4"	250'	75'	Black (BK)	1.47
1"	NYN1.00BK	5/8"	1 3/8"	250'	50'	Black (BK)	1.60
1 1/4"	NYN1.25BK	3/4"	1 1/2"	250'	50'	Black (BK)	1.78
1 1/2"	NYN1.50BK	1"	2"	200'	40'	Black (BK)	2.55
2"	NYN2.00BK	1 1/2"	3"	200'	50'	Black (BK)	2.26

800 323-5140
www.techflex.com



Nylon® is a registered trademark of the DuPont Corporation.





Nylon Multi

Full Coverage, Soft, Supple, Strong and Attractive

Under the hood or across the floor, NYLON MULTI (NM) is the perfect sleeving product for protecting and improving the appearance of wires and cables. NM has been used in military wire harness applications for many years.

NM's fabric-like softness and flexibility hide surprisingly tough specifications. The high coverage sleeving meets or exceeds military specifications A-A-59301. NM is highly resistant to abrasion, cuts, common automotive and marine chemicals, UV damage and vibration. It will not rot or retain moisture.

The wide operating temperature range allows NM to protect delicate wiring in engine compartments and near exhaust systems.

NM creates a unique and attractive retro look when installed on a/v cables.



- **Dense, Full Coverage Construction**
- **Economical and Easy to Install**
- **Cut and Abrasion Resistant**
- **Soft, Pliable, & Quiet**
- **Halogen Free**
- **Resists Gasoline and Engine Chemicals**
- **Wide Operating Temperature Range**



NM's qualities make it a viable choice for defense and military applications that call for flexibility, strength and full coverage protection.

Nominal Size	Part #	Wall Thickness ±0.015"	Standard Spool Put-Ups		Available Colors	Lbs/100'
			Bulk Spool	Shop Spool		
1/8"	NMN0.13BK	.030"	1,000'	225'	Black (BK)	0.33
3/16"	NMN0.19BK	.030"	1,000'	200'	Black (BK)	0.56
1/4"	NMN0.25BK	.030"	500'	200'	Black (BK)	0.79
5/16"	NMN0.31BK	.030"	500'	125'	Black (BK)	0.99
3/8"	NMN0.38BK	.030"	500'	125'	Black (BK)	1.09
1/2"	NMN0.50BK	.030"	250'	100'	Black (BK)	1.74
5/8"	NMN0.63BK	.040"	250'	75'	Black (BK)	2.85
3/4"	NMN0.75BK	.040"	250'	75'	Black (BK)	3.15
7/8"	NMN0.88BK	.040"	200'	50'	Black (BK)	4.35
1"	NMN1.00BK	.050"	200'	50'	Black (BK)	5.15
1 1/4"	NMN1.25BK	.050"	125'	50'	Black (BK)	5.50
1 1/2"	NMN1.50BK	.060"	100'	50'	Black (BK)	6.46
1 3/4"	NMN1.75BK	.060"	100'	50'	Black (BK)	7.73
2"	NMN2.00BK	.060"	100'	50'	Black (BK)	9.01
2 1/2"	NMN2.50BK	.060"	100'	50'	Black (BK)	10.32
3"	NMN3.00BK	.060"	100'	50'	Black (BK)	11.00
Tight Weave						
3/8"	NMT0.38BK	.030"	250'	75'	Black (BK)	1.47



Specialized cutting services available. Contact your Account Representative for more info.



Nylon[®] is a registered trademark of the DuPont Corporation.



800 323-5140
www.techflex.com



Mylar

- **Economical and Easy to Install**
- **Expands up to 150%**
- **Halogen Free**
- **Conductive Mylar for Shielding Applications**

Lightweight, Economical Metallic Alternative

When your needs don't call for the durability or toughness of our CH or CX sleeving, MYLAR (MY) is an ideal, economical alternative. MY is perfect for cosmetic applications and a wide variety of installation methods create dramatic results.

Audiophile cable builders often use MY under other sleeving types to create a unique, custom visual effect. Applications that combine MY with a more robust sleeving will withstand abrasion and general use and still have the custom, "Wow!" effect cable fabricators are looking for.

Braided from thin metallic Mylar strips along with transparent PET monofilament, MY creates a sparkling, highly reflective effect. MY can be used instead of Mylar sheets to wrap and bundle cables.



Light weight and economy make MY an ideal product for designing and tying fishing lures of all types and sizes. Several world records have been set with lures constructed with Techflex sleeving.



Spectacular highlights and unique visual effects are achieved when Mylar is combined with other sleeving types.

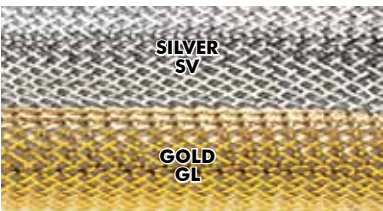

SILVER
SV

GOLD
GL



PEARLESCENT CLEAR
PC

Nominal Size	Part #	Expansion Range		Standard Spool Put-Ups		Available Colors	Lbs/100'
		Min.	Max.	Bulk Spool	Shop Spool		
1/4"	MYN0.25	1/8"	7/16"	1,000'	200'	GL & SV	0.17
1/2"	MYN0.50	1/4"	1"	500'	100'	GL & SV	0.35
3/4"	MYN0.75	5/8"	1 3/4"	250'	75'	GL & SV	0.52

Nominal Size	Part #	Expansion Range		Standard Spool Put-Ups		Available Colors	Lbs/100'
		Min.	Max.	Bulk Spool	Shop Spool		
1/8"	MYE0.13PC	1/16"	5/32"	1,000'	225'	PC	0.08
1/4"	MYE0.25PC	5/32"	5/16"	1,000'	200'	PC	0.10
3/8"	MYE0.38PC	5/16"	15/32"	500'	125'	PC	0.11
1/2"	MYE0.50PC	1/4"	3/4"	500'	100'	PC	0.42

800 323-5140
www.techflex.com



Mylar® is a registered trademark of the DuPont Teijin Films.



Chrome
XC

Chrome

Chrome

The Look of Stainless Steel Braid with an Upside

No installation hassles. No surface abrasion. No ridiculous expense. Just the look of polished braided steel.

These heavy duty metallized Mylar sleeves are ideal for dressing up any application with the look of braided stainless steel. The standard CHROME (CH) has a more open look, with transparent PET braided together with the metallic strands to create a slight glimmer when light strikes it and to allow the color of the application to come through for a special effect. Our X-tra coverage product, CHROME XC (CX), provides fuller coverage with no transparent elements in the braided construction and results in a smooth, continuous metallic shine on any application.

- **Economical and Easy to Install**
- **Cut and Abrasion Resistant**
- **Halogen Free**
- **Resists Gasoline and Engine Chemicals**
- **Ideal for Exposed Applications**
- **Conductive Mylar for Shielding Applications**



Chrome

Nominal Size	Part #	Expansion Range		Standard Spool Put-Ups		Available Colors	Lbs/100'
		Min.	Max.	Bulk Spool	Shop Spool		
1/4"	CHN0.25SV	3/16"	1/2"	500'	125'	Silver (SV)	0.33
3/8"	CHN0.38SV	1/4"	5/8"	250'	100'	Silver (SV)	0.39
1/2"	CHN0.50SV	3/8"	3/4"	250'	80'	Silver (SV)	0.47

Application possibilities include installing clear PVC Heatshrink Tubing (pg. 64) over hoses covered with Chrome or Chrome XC, and also using the Chrome Cable Ties (pg. 70) for a unique effect.

Chrome
XC

Nominal Size	Part #	Expansion Range		Standard Spool Put-Ups		Available Colors	Lbs/100'
		Min.	Max.	Bulk Spool	Shop Spool		
1/4"	CXN0.25SV	1/4"	5/16"	500'	125'	SV & GL	0.25
5/16"	CXN0.31SV	5/16"	1/2"	250'	100'	SV & GL	0.36
1/2"	CXN0.50SV	1/2"	3/4"	250'	80'	SV & GL	0.52
3/4"	CXN0.75SV	3/4"	1 3/8"	200'	40'	SV & GL	0.83
1 1/4"	CXN1.25SV	1 1/4"	2"	100'	30'	SV & GL	1.25
1 1/2"	CXN1.50SV	1 1/2"	3"	100'	25'	SV & GL	1.50



DUPONT Mylar® is a registered trademark of the DuPont Teijin Films.



800 323-5140
www.techflex.com



Flexo 6 Mil

- **Easy to Engineer to Unique Specifications**
- **Economical, Long Lasting Filtration Solutions**
- **Wide Range of Available Materials**
- **Can Be Fabricated into Custom Configurations**
- **Reduced Wall Thickness**

High Density Fine Thread Sleevings

One of the most unique applications for expandable braided sleeving is the filtration of small particles from flowing liquids. Our standard FLEXO 6 MIL (FF) is a great off the shelf solution.

Flexo 6 Mil uses chemical resistant PET fiber to create an ultra flexible sleeve. The small monofilaments bond easily when heated to create lasting shapes, or with one end sealed completely, a durable sock.

Also sold by the name Filter Flexo.



Nominal Size	Part #	Expansion Range		Standard Spool Put-Ups		Available Colors	Lbs/100'
		Min.	Max.	Bulk Spool	Shop Spool		
1/8"	FFN0.13CL	1/16"	1/2"	1,000'	225'	Clear (CL)	0.18
1/4"	FFN0.25CL	3/16"	3/8"	1,000'	200'	Clear (CL)	0.33
5/16"	FFN0.31CL	5/16"	7/16"	500'	150'	Clear (CL)	0.43
3/8"	FFN0.38CL	5/16"	5/8"	500'	125'	Clear (CL)	0.53
1/2"	FFN0.50CL	1/2"	3/4"	500'	100'	Clear (CL)	0.82
5/8"	FFN0.63CL	1/2"	1"	250'	100'	Clear (CL)	1.00



Flexo Thin



Ultra Thin for Specialized Fiber Applications

Braided from ultra fine Nylon monofilament fibers, FLEXO THIN (FT) was created for applications where weight and wall thickness play a critical role. This material is strong enough to bundle multiple cables and fibers while naturally conforming to these types of applications. Many of today's micro optics and precision electronic harnesses use Flexo Thin to flexibly and attractively manage and route tiny assemblies.



1/4" Flexo Thin's enormous expandability allows the management of large bundles of very fine wiring and optical cables.

Nominal Size	Part #	Expansion Range		Standard Spool Put-Ups		Available Colors	Lbs/100'
		Min.	Max.	Bulk Spool	Shop Spool		
1/16"	FTN0.06CL	1/16"	3/16"	1,000'	200'	Clear (CL)	0.013
1/4"	FTN0.25CL	1/8"	1"	500'	200'	Clear (CL)	0.043





Carbon Fiber

Carbon Fiber Sleeve for High Strength Tubular Structures

Fabricators know that resin coated carbon fiber structures are stronger and lighter than virtually any other construction types. CARBON FIBER (CA) construction techniques are appearing in everything from state of the art military and aerospace airframes to hockey sticks, fishing rods and model cars.

Our Carbon Fiber braided sleeving provides a strong, biaxial carbon fiber matrix for stiff, lightweight tubular structures up to 3" in diameter without seams or overlap. The tightly braided thick flexible sleeving will form itself to accommodate elliptical or asymmetrical profiles and provide the full coverage required for radial stability and torsional strength. Carbon Fiber constructions can be cut, drilled, sanded and tooled with commonly available power or hand tools. They can be painted or left with the braid structure exposed.

- **Ideal for Strong Lightweight Tubular Structures**
- **Variety of Diameters, Wall Thicknesses, and Braid Patterns**
- **Fast Turnaround on Custom Requirements**
- **Custom Lengths Available**



	Nominal Size	Part #	Wall Thickness	Expansion Range		Standard Spool Put-Ups		Available Colors	Lbs/100'
				Min.	Max.	Bulk Spool	Shop Spool		
CARBON LIGHT	1/4"	CAL0.25BK	.013"	1/8"	5/16"	500'	100'	Black (BK)	0.38
	1/2"	CAL0.50BK	.013"	1/4"	5/8"	250'	50'	Black (BK)	0.75
	3/4"	CAL0.75BK	.013"	5/16"	7/8"	250'	50'	Black (BK)	1.21
	1"	CAL1.00BK	.013"	3/8"	1 1/16"	200'	50'	Black (BK)	1.51
	1 1/4"	CAL1.25BK	.013"	1/2"	1 1/2"	125'	25'	Black (BK)	1.81
	1 1/2"	CAL1.50BK	.013"	5/8"	1 3/4"	100'	25'	Black (BK)	2.26
CARBON MEDIUM	2"	CAL2.00BK	.013"	3/4"	2 3/16"	100'	25'	Black (BK)	2.72
	1/2"	CAN0.50BK	.020"	1/4"	5/8"	250'	50'	Black (BK)	1.21
	3/4"	CAN0.75BK	.020"	5/16"	7/8"	250'	50'	Black (BK)	1.81
	1"	CAN1.00BK	.020"	7/16"	1 1/16"	200'	50'	Black (BK)	2.42
	1 1/4"	CAN1.25BK	.020"	9/16"	1 1/2"	125'	25'	Black (BK)	3.02
	1 1/2"	CAN1.50BK	.020"	3/4"	1 3/4"	100'	25'	Black (BK)	3.62
CARBON HEAVY	2"	CAN2.00BK	.020"	7/8"	2 3/16"	100'	25'	Black (BK)	4.52
	2 1/2"	CAN2.50BK	.020"	1 1/16"	3"	100'	25'	Black (BK)	5.43
	3/4"	CAH0.75BK	.030"	3/8"	7/8"	250'	50'	Black (BK)	2.72
	1"	CAH1.00BK	.030"	1/2"	1 1/16"	200'	50'	Black (BK)	3.62
	1 1/4"	CAH1.25BK	.030"	11/16"	1 1/2"	125'	25'	Black (BK)	4.83
	1 1/2"	CAH1.50BK	.030"	13/16"	1 3/4"	100'	25'	Black (BK)	5.43
CARBON HEAVY	2"	CAH2.00BK	.030"	1"	2 3/16"	100'	25'	Black (BK)	7.25
	2 1/2"	CAH2.50BK	.030"	1 1/4"	3"	100'	25'	Black (BK)	9.09
	3"	CAH3.00BK	.030"	1 1/2"	3 1/2"	50'	25'	Black (BK)	10.87



Strong, lightweight and stable carbon fiber tubes are easy to machine and finish, and mate well with metal fittings.





Reflex

- **Highly Reflective**
- **Easy to Install**
- **Expands up to 150%**
- **Halogen Free**
- **Resists Gasoline and Engine Chemicals**

Reflects On-Axis Light 360° Up To 675'

FLEXO REFLEX (RF) is our polyethylene terephthalate material braided together with highly reflective 3M Scotchlite retroreflective monofilament. This unique combination provides a high level of wire and cable protection with the added advantage of extraordinary 360 degree, on-axis reflectivity.

RF is up to 1,500 times brighter than plain white under identical conditions and will provide high visibility safety on wires, hoses, cables, bicycle and motorcycle cables, stage wiring and virtually anything else up to 675' away. Reflective even under low light conditions. Patent pending.



Under low light conditions, the retroreflective strands in FLEXO Reflex sleeving reflect light up to 1,500 times more efficiently than bright white sleeving.

Nominal Size	Part #	Expansion Range		Standard Spool Put-Ups		Available Colors	Lbs/100'
		Min.	Max.	Bulk Spool	Shop Spool		
1/8"	RFN0.13CL	1/16"	1/4"	1,000'	100'	Clear (CL)	0.29
1/4"	RFN0.25	3/16"	3/8"	1,000'	100'	CL & BK	0.33
1/2"	RFN0.50	1/4"	1"	500'	100'	CL & BK	0.52
3/4"	RFN0.75	3/8"	1 3/8"	250'	75'	CL & BK	0.63



F6 Reflex



Under low light conditions, the retro-reflective strands in FLEXO Reflex sleeving reflect light up to 1,500 times more efficiently than bright white sleeving.

Reflective, Split Semi Rigid Sleeving For Easy Installation

Ease of installation make F6 REFLEX the most suitable reflective sleeving for applications where disassembly of the components is not a viable option. Just open the lateral split and slip the sleeving over wires or cables. The sleeving will snap back in place and provide an extra measure of safety under low light conditions. F6 Reflex is available in clear. Patents pending.

Nominal Size	Part #	Wall Thickness	Standard Spool Put-Ups		Available Colors	Lbs/100'
			Bulk Spool	Shop Spool		
1/8"	F6R0.13CL	.024"	400'	100'	Clear (CL)	0.20
1/4"	F6R0.25CL	.025"	200'	100'	Clear (CL)	0.60
5/16"	F6R0.31CL	.025"	150'	75'	Clear (CL)	0.75
1/2"	F6R0.50CL	.025"	150'	75'	Clear (CL)	1.40



No special tools or skills required for installation.

800 323-5140
www.techflex.com





NOISE REDUCTION

Flexo NR

Self-Fitting Protective Oversleeve

Flexo Noise Reduction (NR) is a biaxially braided sleeving combining monofilament and multifilament PET yarns to create a full coverage expandable sleeve that substantially reduces noise on wires, tubes and hoses. The lightweight, rugged construction also provides protection from abrasion and vibration that is far superior to foam harness sleeves. NR expands for easy installation over splices and connectors and is flexible enough for tight radius applications.

The braided construction will not hold moisture and drains quickly when immersed. NR is used in body wiring harnesses, instrument panel and lighting wiring, cable & hose assemblies, and other limited access applications where noise reduction is desirable.

Nominal Size	Part #	Expansion Range		Standard Spool Put-Ups		Available Colors	Lbs/100'
		Min.	Max.	Bulk Spool	Shop Spool		
1/8"	NRN0.13BK	1/8"	3/16"	500'	100'	Black (BK)	0.3
1/4"	NRN0.25BK	1/4"	3/8"	500'	100'	Black (BK)	0.5
3/8"	NRN0.38BK	3/8"	1/2"	250'	100'	Black (BK)	0.9
1/2"	NRN0.50BK	1/2"	3/4"	250'	100'	Black (BK)	1.1
5/8"	NRN0.63BK	5/8"	1"	250'	100'	Black (BK)	1.5
3/4"	NRN0.75BK	3/4"	1 1/4"	250'	75'	Black (BK)	2.0
1"	NRN1.00BK	1"	1 5/8"	250'	50'	Black (BK)	2.4



- **Excellent Noise Suppression**
- **Abrasion Resistant**
- **Extremely Lightweight**
- **Attractive Appearance**
- **Does Not Trap Heat or Moisture**
- **Rated to 257°F**
- **Low Temperature Flexibility to -94°F**



F6 Quiet

Nostalgic Look and Feel! Modern Day Performance!

FLEXO F6 QUIET is specially engineered to reduce the noise associated with wire harnesses or cables installed in hard to reach areas such as door panels or dashboards.

The special construction suppresses noise from loose harnesses moving against body or dash panels. F6 Quiet also has a soft and flexible feel, reminiscent of old style cotton loom, making it the perfect product for restoration projects.

Nominal Size	Part #	Wall Thickness ±0.005"	Bulk Spool	Box A	Box B	Available Colors	Lbs/100'
1/4"	F6Q0.25BK	.04"	2,000'	200'	100'	Black (BK)	1.00
3/8"	F6Q0.38BK	.04"	1,000'	150'	75'	Black (BK)	1.80
1/2"	F6Q0.50BK	.04"	800'	150'	75'	Black (BK)	2.00
3/4"	F6Q0.75BK	.04"	500'	100'	50'	Black (BK)	3.00
1 1/4"	F6Q1.25BK	.04"	250'	75'	25'	Black (BK)	4.00



- **Retro Look for Audio Cables**
- **Soft Classic Cotton Loom Feel**
- **Cut and Abrasion Resistant**
- **Cuts Cleanly with Hot Knife**

800 323-5140
www.techflex.com

Part Guard

Protective Plastic Netting

Part Guard (PT) is a high quality industrial polyethylene netting that is ideal for protection and separation of products in all process, handling, shipping and storage applications. The open mesh design eliminated trapping of moisture and protects against rust or corrosion.

Part Guard can be easily cut down to precise lengths, and accommodates a variety of application diameters.

Part Guard is available in an expandable, medium duty type (PGE) or a thicker, non-expandable product (PGN). Each size is defined by a discrete color, allowing quick and easy visual identification of the diameter, and simplifying inventory management of various products.

- **Lightweight**
- **Non-Corrosive**
- **Color Coded Sizes for Easy Identification**
- **Allows Air Circulation**
- **Economical Protection During Shipping or Storage**
- **Reusable**
- **Cuts Easily with Scissors**



Part Guard protects precision bearing surfaces from damage.

Nominal Size	Part #	Wall Thickness	Expansion Range		Standard Spool Put-Up		Available Colors	Lbs/100'
			Min.	Max.	Bulk Spool	Shop Spool		
1/4"	PGE0.25YL	.06"	1/4"	1/2"	3,000'	25'	Yellow (YL)	0.6
1/2"	PGE0.50BL	.06"	1/2"	1"	2,750'	25'	Blue (BL)	0.8
1"	PGE1.00RD	.06"	1"	1 1/2"	1,700'	25'	Red (RD)	1.7
1 1/2"	PGE1.50BK	.06"	1 1/2"	2"	900'	25'	Black (BK)	4.6
2"	PGE2.00WH	.06"	2"	2 1/2"	800'	25'	White (WH)	5.0
1/2"	PGN0.50WH	.08"	1/2"	1 1/4"	500'	100'	White (WH)	1.5
3/4"	PGN0.75OR	.08"	3/4"	1 1/2"	285'	100'	Orange (OR)	3.0
1"	PGN1.00BK	.08"	1"	2"	235'	100'	Black (BK)	3.5
1 1/4"	PGN1.25GN	.08"	1 1/4"	2 1/2"	165'	100'	Green (GN)	5.0
1 1/2"	PGN1.50YL	.08"	1 1/2"	3"	165'	100'	Yellow (YL)	5.2
1 3/4"	PGN1.75GY	.08"	1 3/4"	3 1/2"	135'	100'	Gray (GY)	5.4
2"	PGN2.00BL	.08"	2"	4 1/4"	110'	100'	Blue (BL)	6.4

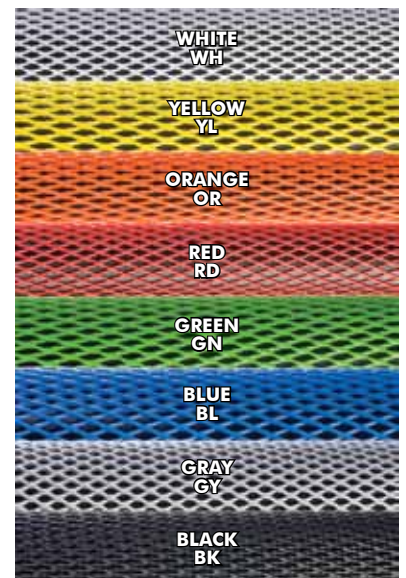



Acrylic Flex Glass

- **Rated to 311°F Class F (155°C)**
- **Grade A (7,000 V) Mil-I-3190/3**
- **Grade C (2,500 V)**
- **Cut and Abrasion Resistant**
- **Excellent Low Temp. Flexibility**
- **Resists Acids and Most Organic Solvents**

Acrylic Resin Coated Fiberglass Sleeving Grade A & C

ACRYLIC FLEX GLASS (AG) sleeving is a heat-treated, tightly braided fiberglass sleeving coated with a dielectric acrylic resin. This durable sleeving will withstand mechanical stress and holds it's dielectric strength on all bends.

Acrylic Flex Glass is used in applications such as relays, radio circuits, transformers, and lead/crossover protection on motors. Highly resistant to acids and solvents, and will withstand tough assembly handling. AG sleeving is recommended for thermal requirements from -94°F to 311°F ranges.



High temperature fiberglass base material makes Flex Glass a great solution for demanding lighting applications.

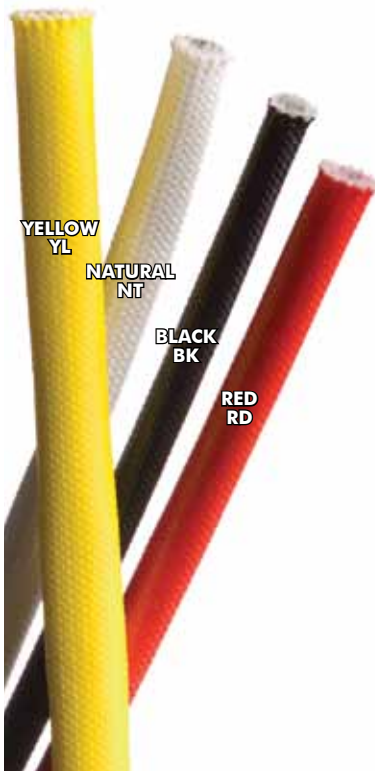

Nominal Size	Diameter	Part #	Grade	Part #	Grade	Standard Spool Put-Ups		Available Colors
						Bulk Spool	Shop Spool	
24	0.022"	AGAG.24	A	AGCG.24	C	500'	250'	NT, BK, YL, RD
22	0.027"	AGAG.22	A	AGCG.22	C	500'	250'	NT, BK, YL, RD
20	0.034"	AGAG.20	A	AGCG.20	C	500'	250'	NT, BK, YL, RD
18	0.042"	AGAG.18	A	AGCG.18	C	500'	250'	NT, BK, YL, RD
16	0.053"	AGAG.16	A	AGCG.16	C	500'	250'	NT, BK, YL, RD
14	0.066"	AGAG.14	A	AGCG.14	C	500'	250'	NT, BK, YL, RD
12	0.085"	AGAG.12	A	AGCG.12	C	250'	100'	NT, BK, YL, RD
11	0.095"	AGAG.11	A	AGCG.11	C	250'	100'	NT, BK, YL, RD
10	0.106"	AGAG.10	A	AGCG.10	C	250'	100'	NT, BK, YL, RD
9	0.118"	AGAG.09	A	AGCG.09	C	250'	100'	NT, BK, YL, RD
8	0.133"	AGAG.08	A	AGCG.08	C	250'	100'	NT, BK, YL, RD
7	0.148"	AGAG.07	A	AGCG.07	C	250'	100'	NT, BK, YL, RD
6	0.166"	AGAG.06	A	AGCG.06	C	250'	100'	NT, BK, YL, RD
5	0.186"	AGAG.05	A	AGCG.05	C	250'	100'	NT, BK, YL, RD
4	0.208"	AGAG.04	A	AGCG.04	C	250'	100'	NT, BK, YL, RD
3	0.234"	AGAG.03	A	AGCG.03	C	250'	100'	NT, BK, YL, RD
2	0.263"	AGAG.02	A	AGCG.02	C	250'	100'	NT, BK, YL, RD
1	0.294"	AGAG.01	A	AGCG.01	C	100'	50'	NT, BK, YL, RD
0	0.330"	AGAG.00	A	AGCG.00	C	100'	50'	NT, BK, YL, RD
3/8"	0.375"	AGA0.38	A	AGC0.38	C	100'	50'	NT, BK, YL, RD
7/16"	0.438"	AGA0.44	A	AGC0.44	C	100'	50'	NT, BK, YL, RD
1/2"	0.500"	AGA0.50	A	AGC0.50	C	100'	50'	NT, BK, YL, RD
5/8"	0.625"	AGA0.63	A	AGC0.63	C	100'	50'	NT
3/4"	0.750"	AGA0.75	A	AGC0.75	C	100'	50'	NT
7/8"	0.875"	AGA0.88	A	AGC0.88	C	100'	50'	NT
1"	1.000"	AGA1.00	A	AGC1.00	C	100'	50'	NT





Silicone Flex Glass

Silicone Coated Fiberglass Sleeving Grade A & C

SILICONE FLEX GLASS (SG) sleeving is engineered with a silicone rubber coating over an insulating fiberglass sleeve. SG is very abrasion resistant and is ideal in heavy duty applications that require outstanding mechanical and electrical properties.

The mechanical properties and high dielectric strength of SG make it the first choice in applications such as transformer lead protection, motor coil leads, component isolation, and power supply wiring.

SG has a high tear strength, slight expandability for easy installation, excellent flex life and resistance to fatigue. It is Class H rated (392°F) with an operating temperature range of -103°F to 428°F. SG shows no discernible effects under exposure of up to 10 megarads of radiation.

- **Rated to 392°F Class H (200°C)**
- **Grade A (7,000 V) Mil-I-3190/6**
- **Grade C (2,500 V)**
- **Cut-Through and Abrasion Resistant**
- **Excellent Low Temp. Flexibility**
- **Resists Inorganic Acids, Alkalis, and Aliphatic Hydrocarbons**



Silicone Flex Glass is ideal for use on high voltage power supplies in precision test equipment.

Nominal Size	Diameter	Part #	Grade	Part #	Grade	Standard Spool Put-Ups		Available Colors
						Bulk Spool	Shop Spool	
24	0.022"	SGAG.24	A	SGCG.24NT	C	500'	250'	WH, BK, NT
22	0.027"	SGAG.22	A	SGCG.22NT	C	500'	250'	WH, BK, NT
20	0.034"	SGAG.20	A	SGCG.20NT	C	500'	250'	WH, BK, NT
18	0.042"	SGAG.18	A	SGCG.18NT	C	500'	250'	WH, BK, NT
16	0.053"	SGAG.16	A	SGCG.16NT	C	500'	250'	WH, BK, NT
14	0.066"	SGAG.14	A	SGCG.14NT	C	500'	250'	WH, BK, NT
12	0.085"	SGAG.12	A	SGCG.12NT	C	250'	100'	WH, BK, NT
10	0.106"	SGAG.10	A	SGCG.10NT	C	250'	100'	WH, BK, NT
9	0.118"	SGAG.09	A	SGCG.09NT	C	250'	100'	WH, BK, NT
8	0.133"	SGAG.08	A	SGCG.08NT	C	250'	100'	WH, BK, NT
7	0.148"	SGAG.07	A	SGCG.07NT	C	250'	100'	WH, BK, NT
6	0.166"	SGAG.06	A	SGCG.06NT	C	250'	100'	WH, BK, NT
5	0.186"	SGAG.05	A	SGCG.05NT	C	250'	100'	WH, BK, NT
4	0.208"	SGAG.04	A	SGCG.04NT	C	250'	100'	WH, BK, NT
3	0.234"	SGAG.03	A	SGCG.03NT	C	250'	100'	WH, BK, NT
2	0.263"	SGAG.02	A	SGCG.02NT	C	250'	100'	WH, BK, NT
1	0.294"	SGAG.01	A	SGCG.01NT	C	100'	50'	WH, BK, NT
0	0.330"	SGAG.00	A	SGCG.00NT	C	100'	50'	WH, BK, NT
3/8"	0.375"	SGA0.38	A	SGC0.38NT	C	100'	50'	WH, BK, NT
7/16"	0.438"	SGA0.44	A	SGC0.44NT	C	100'	50'	WH, BK, NT
1/2"	0.500"	SGA0.50	A	SGC0.50NT	C	100'	50'	WH, BK, NT
5/8"	0.625"	SGA0.63	A	SGC0.63NT	C	100'	50'	WH, BK, NT
3/4"	0.750"	SGA0.75	A	SGC0.75NT	C	100'	50'	WH, BK, NT
7/8"	0.875"	SGA0.88	A	SGC0.88NT	C	100'	50'	WH, BK, NT
1"	1.000"	SGA1.00	A	SGC1.00NT	C	100'	50'	WH, BK, NT





FR Silicone Flex Glass

- **Rated to 392°F Class H (200°C)**
- **Flame Retardant**
- **Grade A (7,000 V) Mil-I-3190/6**
- **Grade C (2,500 V)**
- **Cut and Abrasion Resistant**
- **Excellent Low Temp. Flexibility**
- **Resists Acids, Alkalis, Organic Solvents, & Aliphatic Hydrocarbons**

FR Silicone Coated Fiberglass Sleeving Grade A & C

FLAME RETARDANT SILICONE FLEX GLASS (SF) sleeving is an extremely flexible braided fiberglass sleeve coated with a flame retardant elastometric silicone rubber sheath.

The unique self-fitting construction allows SF sleeving to expand slightly for easy installation, and provides a snug fit for minimum movement and reduced internal abrasion.

SF sleeving is rated to 392°F. (Class H), is abrasion resistant, and maintains it's flexibility in low temperature environments. It is available in a very wide range of sizes, and is ideal for use in appliance assemblies, wire harnesses, transformer leads, power supplies, motor coil and heater leads.



Tomorrow's electric vehicles are more compact with higher power. Flex Glass FR is design to control up to 7,000 volts in tight spaces safely and efficiently.

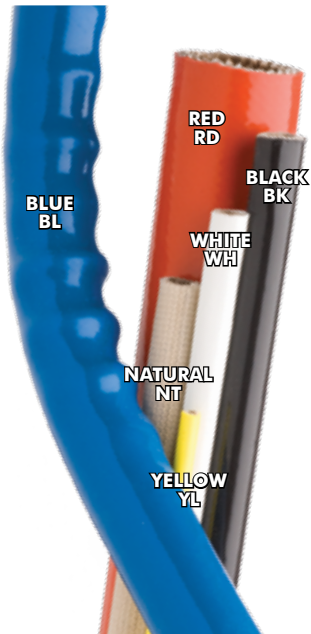

Blue (BL) and Yellow (YL) are custom colors. Call an Account Representative for relevant details regarding custom orders.

Nominal Size	Diameter	Part #	Grade	Available Colors	Part #	Grade	Standard Spool Put-Ups		Available Colors
							Bulk Spool	Shop Spool	
24	0.022"	SFAG.24	A	WH,BK,RD	SFCG.24	C	500'	250'	NT,WH,BK,RD
22	0.027"	SFAG.22	A	WH,BK,RD	SFCG.22	C	500'	250'	NT,WH,BK,RD
20	0.034"	SFAG.20	A	WH,BK,RD	SFCG.20	C	500'	250'	NT,WH,BK,RD
18	0.042"	SFAG.18	A	WH,BK,RD	SFCG.18	C	500'	250'	NT,WH,BK,RD
16	0.053"	SFAG.16	A	WH,BK,RD	SFCG.16	C	500'	250'	NT,WH,BK,RD
14	0.066"	SFAG.14	A	WH,BK,RD	SFCG.14	C	500'	250'	NT,WH,BK,RD
12	0.085"	SFAG.12	A	WH,BK,RD	SFCG.12	C	250'	100'	NT,WH,BK,RD
10	0.106"	SFAG.10	A	WH,BK,RD	SFCG.10	C	250'	100'	NT,WH,BK,RD
9	0.118"	SFAG.09	A	WH,BK,RD	SFCG.09	C	250'	100'	NT,WH,BK,RD
8	0.133"	SFAG.08	A	WH,BK,RD	SFCG.08	C	250'	100'	NT,WH,BK,RD
7	0.148"	SFAG.07	A	WH,BK,RD	SFCG.07	C	250'	100'	NT,WH,BK,RD
6	0.166"	SFAG.06	A	WH,BK,RD	SFCG.06	C	250'	100'	NT,WH,BK,RD
5	0.186"	SFAG.05	A	WH,BK,RD	SFCG.05	C	250'	100'	NT,WH,BK,RD
4	0.208"	SFAG.04	A	WH,BK,RD	SFCG.04	C	250'	100'	NT,WH,BK,RD
3	0.234"	SFAG.03	A	WH,BK,RD	SFCG.03	C	250'	100'	NT,WH,BK,RD
2	0.263"	SFAG.02	A	WH,BK,RD	SFCG.02	C	250'	100'	NT,WH,BK,RD
1	0.294"	SFAG.01	A	WH,BK,RD	SFCG.01	C	100'	50'	NT,WH,BK,RD
0	0.330"	SFAG.00	A	WH,BK,RD	SFCG.00	C	100'	50'	NT,WH,BK,RD
3/8"	0.375"	SFA0.38	A	WH,BK,RD	SFC0.38	C	100'	50'	NT,WH,BK,RD
7/16"	0.438"	SFA0.44	A	WH,BK,RD	SFC0.44	C	100'	50'	NT,WH,BK,RD
1/2"	0.500"	SFA0.50	A	WH,BK,RD	SFC0.50	C	100'	50'	NT,WH,BK,RD
5/8"	0.625"	SFA0.63	A	WH,BK,RD	SFC0.63	C	100'	50'	NT,WH,BK,RD
3/4"	0.750"	SFA0.75	A	WH,BK,RD	SFC0.75	C	100'	50'	NT,WH,BK,RD
7/8"	0.875"	SFA0.88	A	WH,BK,RD	SFC0.88	C	100'	50'	NT,WH,BK,RD
1"	1.000"	SFA1.00	A	WH,BK,RD	SFC1.00	C	100'	50'	NT,WH,BK,RD
1 1/4"	1.250"	SFA1.25	A	WH,BK,RD	N/A	N/A	100'	50'	N/A
1 1/2"	1.500"	SFA1.50	A	WH,BK,RD	N/A	N/A	100'	50'	N/A



HW Silicone Flex Glass

Heavy Wall Silicone Coated Fiberglass Sleeving

HEAVY WALL FLEX GLASS (SG) is engineered from a high quality braided fiberglass sleeve surrounded by a heavy silicone rubber coating. SG expands slightly for easy installation, and is tough and flexible enough for use in tight radius applications. The silicone coating will expand and flex without cracks or fractures, and the treated fiberglass minimizes end fray and dusting during assembly and use. Heavy Wall Flex Glass resists dielectric breakdown caused by operational stresses.

SG is highly abrasion resistant and remains flexible in low temperature applications. It is also resistant to common chemicals, inorganic acids, alkalis and aliphatic hydrocarbons. Rated to 392°F. (Class H), SG is in extensive use in dry-type transformer applications, and is ideal for terminal insulation and protection in a wide range of operating environments.

- **Rated to 392°F Class H (200°C)**
- **15,000 V**
- **Excellent Low Temp. Flexibility**
- **Low Temp. Brittle Point Below -121°F**
- **Resists Inorganic Acids, Alkalis, and Aliphatic Hydrocarbons**

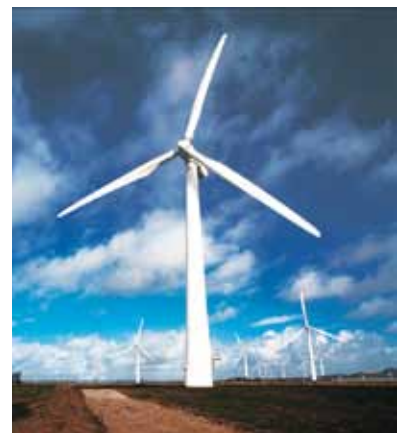

Nominal Size	Diameter	Part #	Grade	Standard Spool Put-Ups		Available Colors
				Bulk Spool	Shop Spool	
14	0.066"	SGHG.14RD	15,000 V	500'	N/A	Red (RD)
12	0.085"	SGHG.12RD	15,000 V	250'	N/A	Red (RD)
10	0.106"	SGHG.10RD	15,000 V	250'	N/A	Red (RD)
9	0.118"	SGHG.09RD	15,000 V	250'	N/A	Red (RD)
8	0.133"	SGHG.08RD	15,000 V	250'	N/A	Red (RD)
7	0.148"	SGHG.07RD	15,000 V	250'	N/A	Red (RD)
6	0.166"	SGHG.06RD	15,000 V	250'	N/A	Red (RD)
5	0.186"	SGHG.05RD	15,000 V	250'	N/A	Red (RD)
4	0.208"	SGHG.04RD	15,000 V	250'	N/A	Red (RD)
3	0.234"	SGHG.03RD	15,000 V	250'	N/A	Red (RD)
2	0.263"	SGHG.02RD	15,000 V	250'	N/A	Red (RD)
1	0.294"	SGHG.01RD	15,000 V	250'	N/A	Red (RD)
0	0.330"	SGHG.00RD	15,000 V	100'	N/A	Red (RD)
3/8"	0.375"	SGH0.38RD	15,000 V	100'	N/A	Red (RD)
7/16"	0.438"	SGH0.44RD	15,000 V	100'	N/A	Red (RD)
1/2"	0.500"	SGH0.50RD	15,000 V	100'	N/A	Red (RD)
5/8"	0.625"	SGH0.63RD	15,000 V	100'	N/A	Red (RD)
3/4"	0.750"	SGH0.75RD	15,000 V	100'	N/A	Red (RD)
7/8"	0.875"	SGH0.88RD	15,000 V	50'	N/A	Red (RD)
1"	1.000"	SGH1.00RD	15,000 V	50'	N/A	Red (RD)



Polyolefin

- **Shrink Temp. 194°F**
- **Flame Retardant**
- **Versatile & Economical Termination Solution**
- **Wide Selection of Sizes and Colors**
- **Resists Common Automotive Chemicals**
- **Easily Installs Over Connectors & Splices**
- **Mil-I-23053/5**

Shrinkflex heatshrink tubing is the ideal way to create a tight, professional finish on any wire, hose or cable management project.

2:1 Polyolefin Heatshrink Tubing

When economy is the driving force, 2:1 Shrinkflex heatshrink tubing is the answer. Not as versatile as a high ratio shrink product, 2:1 will still slide easily over small inline splices and connectors and provide a tight seal in many applications.



Shrinkflex works great for color coding and wire harnessing applications.

Nominal Size	Part #	Unshrunk Diameter	Shrunk Diameter	Standard Spool Put-Ups		Available Colors	Lbs/100'
				Bulk Spool	Shop Spool		
3/64"	H2N0.05	1.3mm	0.6mm	500'	25'	11	0.16
1/16"	H2N0.06	1.8mm	0.8mm	500'	25'	11	0.22
1/8"	H2N0.13	3.4mm	1.6mm	500'	25'	11	0.43
3/16"	H2N0.19	5.0mm	2.4mm	500'	25'	BK & CL	0.60
1/4"	H2N0.25	6.4mm	3.2mm	250'	25'	11	1.04
3/8"	H2N0.38	9.5mm	4.8mm	200'	25'	11	1.31
1/2"	H2N0.50	12.7mm	6.4mm	200'	25'	11	1.52
5/8"	H2N0.63	16.7mm	8.0mm	100'	25'	11	2.12
3/4"	H2N0.75	19.1mm	9.4mm	100'	25'	11	2.58
1"	H2N1.00	25.7mm	12.7mm	100'	25'	11	3.74
1 1/2"	H2N1.50	38.1mm	19.1mm	100'	25'	11	5.53
2"	H2N2.00	51.0mm	25.4mm	100'	25'	11	8.25
3"	H2N3.00	76.2mm	38.1mm	100'	25'	BK,CL,GN,GY,RD,WH,YL	13.15
4"	H2N4.00BK	101.6mm	50.8mm	100'	25'	BK	23.50

3:1 Polyolefin Heatshrink Tubing

The high shrink ratio of 3:1 Shrinkflex heatshrink tubing ensures that the tubing will slip over large connectors or plugs and still provide a tight, professional seal.



Convenient packaging.

Nominal Size	Part #	Unshrunk Diameter	Shrunk Diameter	Standard Spool Put-Ups		Available Colors	Lbs/100'
				Bulk Spool	Shop Spool		
1/16"	H3N0.06	1.5mm	0.5mm	500'	25'	11	0.18
1/8"	H3N0.13	3.0mm	1.0mm	500'	25'	11	0.37
3/16"	H3N0.19	4.5mm	1.5mm	500'	25'	11	0.55
1/4"	H3N0.25	6.0mm	2.0mm	250'	25'	11	0.74
3/8"	H3N0.38	9.0mm	3.0mm	200'	25'	11	1.01
1/2"	H3N0.50	12.0mm	4.0mm	200'	25'	11	1.28
3/4"	H3N0.75	18.8mm	6.0mm	200'	25'	11	1.87
1"	H3N1.00	24.0mm	8.0mm	100'	25'	11	2.86
1 1/2"	H3N1.50	38.0mm	13.0mm	100'	25'	11	4.51
2"	H3N2.00	50.0mm	17.0mm	100'	25'	11	6.33
3"	H3N3.00	75.0mm	25.4mm	100'	20'	BK	10.33



Printing

Shrinkflex - printed with your logo or part number for branding and identification.

Techflex is happy to make this unique service available to our customers. Our proprietary heatshrink printing process allows you to select from our available combinations of heatshrink products and design your own customized heatshrink tubing.

You can choose from any of our 11 tubing colors (pg. 62), and 9 ink colors as follows: Black, Blue, Gold, Green, Purple, Red, Silver, White, and Yellow.

Your finished art will be prepared by our Graphics Department and printed on our high resolution equipment. Please contact your Account Representative for more details.

- Printing
- Logos
- ID Numbers
- Cut Parts
- JIT



Put your company's brand where your customers will see it!



Polyolefin

- Shrink Temp. 194°F
- Flame Retardant
- Versatile & Economical Termination Solution
- Resists Common Automotive Chemicals
- Easily Installs Over Connectors & Splices

4:1 Polyolefin Heatshrink Tubing

4:1 Shrinkflex heatshrink tubing is the most versatile of the heatshrink products. The high shrink ratio ensures that the tubing will slip over large connectors or plugs and still provide a tight, professional seal.



Nominal Size	Part #	Unshrunk Diameter	Shrunk Diameter	Standard Spool Put-Ups		Available Colors	Lbs/100'
				Bulk Spool	Shop Spool		
1/2"	H4N0.50BK	12.0mm	3.0mm	200'	25'	Black (BK)	1.17
3/4"	H4N0.75BK	19.0mm	4.5mm	200'	25'	Black (BK)	2.75
1"	H4N1.00BK	25.4mm	7.0mm	200'	25'	Black (BK)	3.25
1 1/4"	H4N1.25BK	32.0mm	8.0mm	200'	25'	Black (BK)	4.00
1 1/2"	H4N1.50BK	38.0mm	9.5mm	200'	25'	Black (BK)	4.25



PVC

Ultra Clear 2:1 PVC Heatshrink Tubing

Shrinks to 1/2 it's original diameter. Ultra clear PVC heatshrink tubing is ideal for application where complete transparency is required.

Perfect for protecting exposed wires and cables on motorcycles and custom automobiles. Resists gasoline, oil, and common chemicals; provides protection from abrasion and severe environments.

Stays clear when shrunk.

Nominal Size	Part #	Unshrunk Diameter	Shrunk Diameter	Standard Spool Put-Ups		Available Colors	Lbs/100'
				Bulk Spool	Shop Spool		
1/4"	H2P0.25CL	6.4mm	3.2mm	200'	25'	Clear (CL)	0.60
5/16"	H2P0.31CL	8.0mm	4.0mm	200'	25'	Clear (CL)	0.70
3/8"	H2P0.38CL	9.5mm	4.8mm	200'	25'	Clear (CL)	0.80
1/2"	H2P0.50CL	12.7mm	6.4mm	200'	25'	Clear (CL)	1.10
5/8"	H2P0.63CL	15.9mm	7.9mm	200'	25'	Clear (CL)	1.16
3/4"	H2P0.75CL	19.1mm	9.5mm	200'	25'	Clear (CL)	1.90
1"	H2P1.00CL	25.4mm	12.7mm	200'	25'	Clear (CL)	3.00
2"	H2P2.00CL	50.8mm	25.4mm	100'	25'	Clear (CL)	

*Contact your Account Representative for heatshrink cutting & printing services.

Fabric

2:1 Fabric Heatshrink Tubing

Shrinks to 1/2 it's original diameter. Fabric heatshrink tubing, a unique mixture of Polyolefin and Polyester yarns, is the ideal way to form the only shrinkable fabric of its kind. The woven construction makes this product extremely flexible and resistant to trapping water, heat and humidity. Provides outstanding abrasion, chafing and cutting protection, even at high temperatures.

Shrinkflex fabric tubing is designed primarily to provide mechanical abrasion protection for components such as rubber hoses, plastic pipes, and harness wiring bundles. Also suitable for other applications, such as noise and rattle suppression.

Nominal Size	Part #	Unshrunk Diameter	Shrunk Diameter	Standard Spool Put-Ups		Available Colors	Lbs/100'
				Bulk Spool	Shop Spool		
1/2"	H2F0.48BK	12mm	6mm	100'	25'	Black (BK)	1.15
3/4"	H2F0.79BK	20mm	10mm	100'	25'	Black (BK)	1.61
1"	H2F0.98BK	25mm	12.5mm	100'	25'	Black (BK)	1.71
1 3/16"	H2F1.18BK	30mm	15mm	100'	25'	Black (BK)	2.13
1 3/8"	H2F1.38BK	35mm	17.5mm	100'	25'	Black (BK)	2.35
1 1/2"	H2F1.58BK	40mm	20mm	100'	25'	Black (BK)	2.66
2"	H2F1.97BK	50mm	25mm	100'	25'	Black (BK)	3.44
2 3/8"	H2F2.36BK	60mm	30mm	100'	25'	Black (BK)	4.11
2 3/4"	H2F2.75BK	70mm	35mm	100'	25'	Black (BK)	4.69
3 1/8"	H2F3.15BK	80mm	40mm	100'	25'	Black (BK)	5.29

- **Shrink Temp. 176°F**
- **Highly Flexible**
- **Resists Common Automotive Chemicals**
- **Easily Installs Over Connectors & Splices**
- **Halogen Free**



Diesel Resistant

2:1 Diesel Resistant Heatshrink Tubing

Diesel resistant heatshrink tubing is the ideal way to create a tight, professional finish on any wire, hose or cable management project. Once shrunk, the tubing will hold its reduced state even in elevated temperatures. H2D is resistant to aviation and diesel fuels, hydraulic fluids and lubrication oils. It will protect wires, solder joints, terminals, connections and components from most industrial fuels and abrasion.

Nominal Size	Part #	Unshrunk Diameter	Shrunk Diameter	Standard Spool Put-Ups		Available Colors	Lbs/100'
				Bulk Spool	Shop Spool		
1/8"	H2D0.13BK	3.2mm	1.6mm	500'	25'	Black (BK)	0.70
3/16"	H2D0.19BK	4.8mm	2.4mm	250'	25'	Black (BK)	1.00
1/4"	H2D0.25BK	6.4mm	3.2mm	250'	25'	Black (BK)	1.20
3/8"	H2D0.38BK	9.6mm	4.8mm	200'	25'	Black (BK)	1.75
1/2"	H2D0.50BK	12.8mm	6.4mm	100'	25'	Black (BK)	2.75
3/4"	H2D0.75BK	19.3mm	9.5mm	100'	25'	Black (BK)	4.75
1"	H2D1.00BK	25.4mm	12.7mm	100'	25'	Black (BK)	8.80
1 1/4"	H2D1.25BK	31.8mm	15.9mm	100'	25'	Black (BK)	
1 1/2"	H2D1.50BK	38.2mm	19.1mm	100'	25'	Black (BK)	

- **Shrink Temp. 302°F**
- **Heavy Wall, Flexible Elastomer Polyolefin Tubing**
- **High Resistance to Aviation Fuels, Diesel Fuels and Oils**

*Contact your Account Representative for heatshrink cutting & printing services.

800 323-5140
www.techflex.com

Dual Wall Adhesive

- Shrink Temp. 194°F
- Flame Retardant
- Versatile & Economical Termination Solution
- Resists Common Automotive Chemicals
- Easily Installs Over Connectors & Splices
- Excellent Electrical Properties
- Protects from Fluids, Moisture & Corrosion

2:1 and 3:1 Dual Wall Adhesive Heatshrink Tubing

Dual wall adhesive lined polyolefin heatshrink tubing is ideal for producing strong, weather tight seals on any heatshrink installation. During the application of heat from a heat gun or other heat source, the inner adhesive wall melts and flows, creating an adhesion layer to ensure a snug fit to your harness or connector.

Adhesive lined heatshrink comes in 2:1 and 3:1 shrink ratio, and it is available in 4' sticks.



Seals and protects a wide variety of electrical applications, including wire splices, breakouts, and connectors-to-cable transitions.



Shrinks to 1/2 it's original diameter

Nominal Size	Part #	Unshrunk Diameter	Shrunk Diameter	Bulk Box Put Up/4' Pcs.	Shop Box Put Up/4' Pcs.	Available Colors	Lbs/10Pcs.
1/8"	H2A0.13	3.2mm	1.6mm	250	25	BK,CL	
1/4"	H2A0.25	6.4mm	3.2mm	250	25	BK,CL	
3/8"	H2A0.38	9.6mm	4.8mm	250	25	WH,BK,RD	
1/2"	H2A0.50	12.7mm	6.4mm	200	25	WH,BK,CL,RD	
3/4"	H2A0.75	19.1mm	9.6mm	80	25	WH,BK,RD	
1"	H2A1.00	25.4mm	12.7mm	50	25	WH,BK,RD	
1 1/2"	H2A1.50	38.1mm	19.1mm	15	5	BK	

Shrinks to 1/3 it's original diameter

Nominal Size	Part #	Unshrunk Diameter	Shrunk Diameter	Bulk Box Put Up/4' Pcs.	Shop Box Put Up/4' Pcs.	Available Colors	Lbs/10Pcs.
1/8"	H3A0.13	3.0mm	1.0mm	250	25	WH,BK,CL,RD	
3/16"	H3A0.19	4.8mm	1.5mm	250	25	WH,BK,CL,RD	
1/4"	H3A0.25	6.0mm	2.0mm	250	25	WH,BK,CL,RD	0.35
3/8"	H3A0.38	9.0mm	3.0mm	250	25	WH,BK,CL,RD	0.55
1/2"	H3A0.50	12.0mm	4.0mm	200	25	WH,BK,CL,RD	0.75
3/4"	H3A0.75	19.0mm	6.0mm	80	25	WH,BK,CL,RD	1.65
1"	H3A1.00	24.0mm	8.0mm	50	25	WH,BK,CL,RD	2.15
2"	H3A2.00	50.0mm	17.0mm	15	5	WH,BK,CL,RD	5.25



*Contact your Account Representative for heatshrink cutting & printing services.

Viton

2:1 Viton® - Flexible Heatshrink Tubing

Viton is a rubber-like, highly fluid resistant, flame retardant fluoro-elastomer heat-shrinkable tubing with high solvent resistance. The product is recommended for bundling, harnessing and environmental protection within engine compartments.

Nominal Size	Part #	Unshrunk Diameter	Shrunk Diameter	Standard Spool Put-Ups		Available Colors	Lbs/100'
				Bulk Spool	Shop Spool		
1/8"	H2V0.13BK	3.2mm	1.6mm	200'	100'	Black (BK)	1.26
3/16"	H2V0.19BK	4.8mm	2.4mm	200'	100'	Black (BK)	1.45
1/4"	H2V0.25BK	6.4mm	3.2mm	200'	100'	Black (BK)	1.68
3/8"	H2V0.38BK	9.5mm	4.7mm	200'	100'	Black (BK)	2.27
1/2"	H2V0.50BK	12.7mm	6.4mm	100'	50'	Black (BK)	2.29
5/8"	H2V0.63BK	16.0mm	8.0mm	100'	50'	Black (BK)	
3/4"	H2V0.75BK	19.1mm	9.5mm	100'	50'	Black (BK)	4.14
7/8"	H2V0.88BK	22.4mm	11.0mm	50'	25'	Black (BK)	
1"	H2V1.00BK	25.4mm	12.7mm	50'	25'	Black (BK)	5.73
1 1/4"	H2V1.25BK	31.7mm	15.7mm	50'	25'	Black (BK)	
1 1/2"	H2V1.50BK	38.1mm	19.1mm	50'	25'	Black (BK)	
2"	H2V2.00BK	50.8mm	25.4mm	50'	25'	Black (BK)	

- **Shrink Temperature 248°F (120°C)**
- **Mil-I-DTL-23053/13**
- **Flame Retardant**
- **Resistant to Highly Corrosive Acids, Fluids, Fuels & Solvents**
- **High Operating Temp. 392°F (200°C) For Extreme Working Conditions**

Viton® is a registered trademark of DuPont Performance Elastomers.
Kynar® is a registered trademark of the Arkema Corporation.

Kynar

2:1 Kynar® - Semi-Rigid Heatshrink Tubing

Kynar is a highly flame-retardant tubing that is tough and abrasion resistant in mechanical environments. The product is recommended for applications for strain relieving components such as soldered connections and splices.

Nominal Size	Part #	Unshrunk Diameter	Shrunk Diameter	Bulk Box Put Up/4'Pcs.	Shop Box Put Up/4'Pcs.	Available Colors	Lbs/10Pcs.
3/64"	H2K0.05	1.2mm	0.6mm	200	25	CL & BK	0.03
1/16"	H2K0.06	1.6mm	0.8mm	200	25	CL & BK	0.05
3/32"	H2K0.09	2.4mm	1.2mm	200	25	CL & BK	0.06
1/8"	H2K0.13	3.2mm	1.6mm	200	25	CL & BK	0.07
3/16"	H2K0.19	4.8mm	2.4mm	200	25	CL & BK	0.10
1/4"	H2K0.25	6.4mm	3.2mm	200	25	CL & BK	0.15
3/8"	H2K0.38	9.5mm	4.7mm	200	25	CL & BK	0.25
1/2"	H2K0.50	12.7mm	6.4mm	100	25	CL & BK	0.30
3/4"	H2K0.75	19.1mm	9.5mm	50	25	CL & BK	0.50
1"	H2K1.00	25.6mm	12.7mm	50	25	CL & BK	0.80

- **Mil-I-DTL-23053/8**
- **VW-1, UL 224, CSA**

*Contact your Account Representative for heatshrink cutting & printing services.

Shield

- **Mil-I-DTL-23053/5**
- **Flame Retardant**
- **Excellent High Frequency EMI Shielding**
- **RoHS**
- **Easily Installs Over Connectors & Splices**

2:1 Shield Heatshrink Tubing

2:1 Shield heatshrink tubing is a unique combination of Polyolefin and conductive cloth, with a high frequency EMI shielding properties. This product, a flame retardant and fluid resistant tubing, is a perfect solution for protecting your wire & cable bundles.

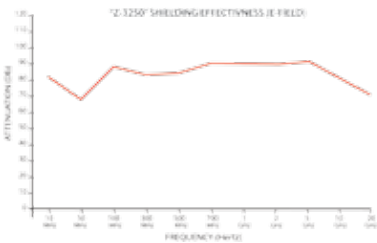

Nominal Size	Part #	Unshrunk Diameter	Shrunk Diameter	Bulk Box Put Up/4' Pcs.	Shop Box Put Up/4' Pcs.	Available Colors	Lbs/10Pcs.
3/16"	H2C0.19BK	4.8mm	2.4mm	12	2	Black (BK)	0.31
1/4"	H2C0.25BK	6.4mm	3.2mm	12	2	Black (BK)	0.50
3/8"	H2C0.38BK	9.5mm	4.8mm	12	2	Black (BK)	0.63
1/2"	H2C0.50BK	12.7mm	6.4mm	12	2	Black (BK)	0.75
3/4"	H2C0.75BK	19.1mm	9.5mm	12	2	Black (BK)	1.00
1"	H2C1.00BK	25.4mm	12.7mm	12	2	Black (BK)	1.50
1 1/2"	H2C1.50BK	38.1mm	19.1mm	12	2	Black (BK)	2.25

Glossy Polyolefin

- **Shrink Temp. 239°F**
- **Attractive Glossy Surface**
- **Excellent UV Resistance**
- **Good Electrical Properties & Chemical Resistance**

2:1 Glossy Polyolefin Heatshrink Tubing

2:1 Glossy Polyolefin heatshrink tubing is the ideal way to create a tight, professional finish on any wire, hose or cable management project. Once shrunk, the tubing will hold its reduced state even in elevated temperatures. The wide range of diameters and the attractive glossy finish makes this heatshrink a perfect solution for any termination application.



Nominal Size	Part #	Unshrunk Diameter	Shrunk Diameter	Standard Spool Put-Ups		Available Colors	Lbs/100'
				Bulk Spool	Shop Spool		
1/8"	H2G0.13	3.2mm	1.6mm	500'	25'	RD,WH,BK,CL	0.43
3/16"	H2G0.19	4.8mm	2.4mm	200'	25'	RD,WH,BK,CL	0.60
1/4"	H2G0.25	6.4mm	3.2mm	200'	25'	RD,WH,BK,CL	1.04
3/8"	H2G0.38	9.5mm	4.7mm	200'	25'	RD,WH,BK,CL	1.31
1/2"	H2G0.50	12.7mm	6.4mm	200'	25'	RD,WH,BK,CL	1.52
3/4"	H2G0.75	19.1mm	9.5mm	100'	25'	RD,WH,BK,CL	2.58
1"	H2G1.00	25.4mm	12.7mm	100'	25'	RD,WH,BK,CL	3.74
1 1/2"	H2G1.50	38.1mm	19.1mm	100'	25'	RD,WH,BK,CL	5.53
2"	H2G2.00	50.8mm	25.4mm	100'	25'	RD,WH,BK,CL	8.25

800 323-5140
www.techflex.com

*Contact your Account Representative for heatshrink cutting & printing services.

How to work with heatshrink tubing



Measure the heatshrink tubing to length and cut with a scissor. The thickness of your bundle, as well as the desired final appearance, will determine the length of the tubing you cut. Generally, a piece 1 1/2" - 2" long will accommodate almost any need (such as this bundle of network cables). Single wires, or smaller bundles, require shorter pieces.



Slip the tubing over the bundle and position it so that both the sleeved and unsleeved portions are sufficiently covered. Notice the small pieces of tubing installed on single wires as part of a color coding system. If your project requires multiple operations, always work up from the smallest to the largest bundle.



Gently apply heat from a heat gun, hair dryer or torch with an appropriate attachment. Keep the heat source far enough away so that hot metal or direct flame don't come in contact with the tubing, wires or sleeving. Move the heat around the bundle to prevent damaging the sleeving and to ensure that all areas of the tubing have been shrunk. Once cooled, your installation is complete.



**Milwaukee
High Quality
Heat Guns
& Accessories**

Production quality heat guns from one of the finest names in tools. These high quality guns will provide years of dependable service under the most intensive conditions. High strength, impact resistant cases with heavy duty motors and heating elements.

- Dual Temp - HGD8975-6
- Variable Temp LED Display - HGL8988-20
- Accessory Kit - HGA49-80-0300

Techflex helps your projects fly with Shrinkflex and Flexo Sleeving!

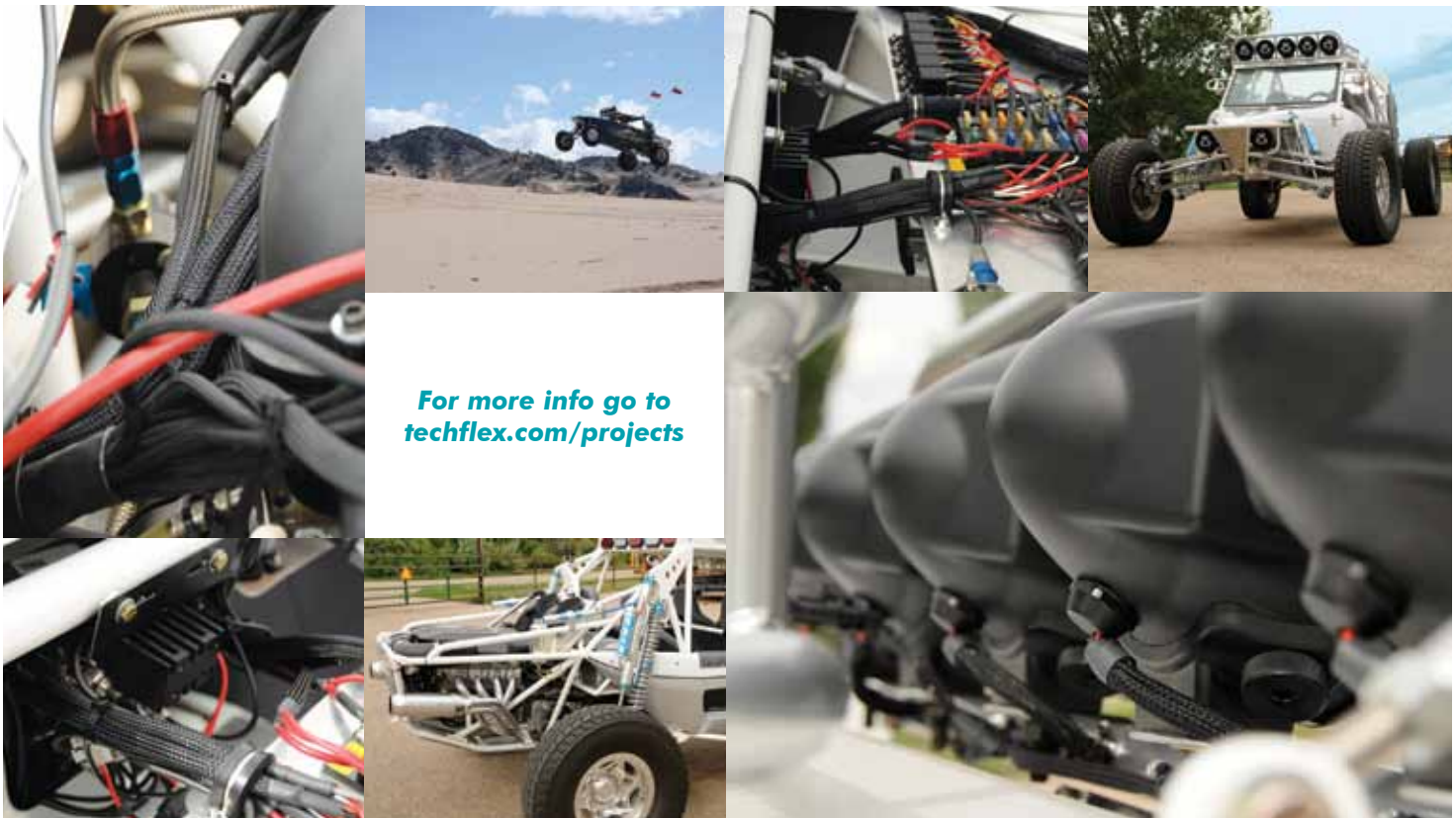

**For more info go to
techflex.com/projects**

Cable Ties & Straps

Cable Ties and Velcro® Straps are economical and easy to field install, and provide termination solutions that produce a neat appearance on any cable management application.

Velcro® Brand Straps

Reusable and flexible One-Wrap brand straps are perfect for temporary management of cords, cables and wires. Can be reused hundreds of times. Available in a wide range of colors and sizes (width=3/4").



- 5" - VST5.00
- 6" - VST6.00
- 8" - VST8.00
- 12" - VST12.0
- 18" - VST18.0



FR Velcro® Straps

Flame Retardant Velcro® brand straps are suitable for plenum applications and are UL flame rated (width=3/4"). Black (BK) and Cranberry (CR).

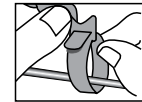

- 8" - VSF8.00
- 12" - VSF12.0
- 18" - VSF18.0

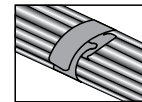

Low Profile Cable Ties

These cable ties are safer, smoother and stronger than traditional cable ties. You can apply them to their bundle with side cutters or any industry installation tool. Manufactured from dependable 6/6 Nylon®, these unique cable ties are available in 7" and 14" lengths in either Natural (Clear) or UV stabilized Black.

- 7" - LPR7.00
- 14" - LPR14.0



Chrome

Chrome Ties

Finish your custom application with genuine chrome cable ties from Techflex.

- 7 1/2" - CBC7.50SV

Stainless Steel Cable Ties

High temperature stainless steel cable ties are great for harsh environments. Perfect for installing heavy duty and high temp sleeving.



- 5" - 100lb SSS5.00SV 250lb SSH5.00SV
- 7 1/2" - 100lb SSS7.50SV 250lb SSH7.50SV
- 14 1/2" - 100lb SSS14.5SV 250lb SSH14.5SV
- 20" - 100lb SSS20.0SV 250lb SSH20.0SV
- 27" - 100lb SSS27.0SV 250lb SSH27.0SV

Stainless Steel Cable Tie Gun

Cable Tie Gun for steel ties cuts off excess strap when the selected tension setting is achieved. Produces consistent tension from tie to tie and saves installation time with one easy action.

- Cable Tie Gun - SSTG

High Strength Nylon Cable Ties

Easy to use nylon cable ties are perfect for virtually any bundling or management application. Economical, yet strong ties resist heat and abrasion.

- 7 1/2" - TYR7.50 Metal Barb
- 3 3/4" - TYR3.75 Metal Barb
- 7 1/2" - CBR7.50 Plastic Barb*
- 3 3/4" - CBR3.75 Plastic Barb*



Working Effectively With Tape

Sure, you could just wrap some tape around the ends of your sleeving and call it a day. It won't look great, but it'll work just fine. However, with just a few more minutes work, you can achieve a clean, invisible termination solution with a unique visual effect. This is ideal when the other end of the installation will be hidden under a plug or inside a cabinet.



Measure the sleeving and mark the measurement with a pen or marker. Add an additional 1 1/2 - 2 inches and cut the extended length of sleeving.



Slip the additional length of sleeving over the end of your application so that the mark is at the spot on the installation where you want the sleeving to end. On this low pressure air hose, it's just below the connector.



Starting at the line, take a few tight turns of tape down the application so that it covers the sleeving and extends about 1 1/2" on the application. Make sure the tape is smooth and tight. Cut the end and press down for a smooth finish.

Push the sleeving down over itself and the tape and keep pushing until the other end of the sleeving falls into place at the far end of the application. If there are any sharp edges or loose wires on the ends, temporarily wrap them with tape to avoid snags.



This system creates a clean termination with a slight flare at the end.

This installation process only works at one end of your application. To finish the other end, you'll have to use another termination procedure.



3M 2242 Self Bonding Tape

Linerless rubber splicing tape. Waterproof and flame retardant. Ideal for moisture sealing and insulating.

3M 2242 Tape - 3M20.75



3M Vinyl Electrical Tape

Standard, general purpose vinyl tape for use in applications not subject to extreme heat, cold, abrasion or chemical/UV exposure. Ideal for interior applications in the home, office or shop. 3/4" x 66'.

3M Vinyl Tape - MMN0.75



Wrap & Seal Tape

High strength tape works on dirty or wet surfaces. Ideal for automotive and marine hoses. Self-sealing and waterproof.

Wrap & Seal Tape - WNS1.00



Plastic Dip

Brush on or dip to permanently seal sleeving ends on hoses, cables or wires. Available in 2 sizes.

4 oz. Blister Pack - PD4OZ
14.5 oz. Bulk Can - PD14OZ





Seal Silicone Tape

- **Self-Fusing**
- **Air & Moisture Tight Seal**
- **Prevents Corrosion**
- **No Adhesive, Bonds Only to Itself**
- **Resists Weathering**
- **Conforms to Irregular Shapes**
- **Elastic Memory Seal**
- **Cures in 24 Hours at Room Temperature**

Meet The New King Of Problem Solving!

Seal self-fusing silicone tape is unique adhesive free product that quickly fuses to itself to create a and corrosion resistant continuous seal for electrical insulation, pipe and hose repair, or anywhere a quick and residue free wrap is needed.



Seal Silicone Tape creates an airtight/watertight seal around even irregularly shaped applications, and the high insulation values make it useful in repairing cracked or damaged insulation in Class A and B applications.

Ideal to keep in a toolbox for emergency repairs on wires or hoses, as a residue free solution to coil extension cords, ropes, and cables, and for a waterproof, heat and chemical resistant wrap for wiring harnesses and splices.

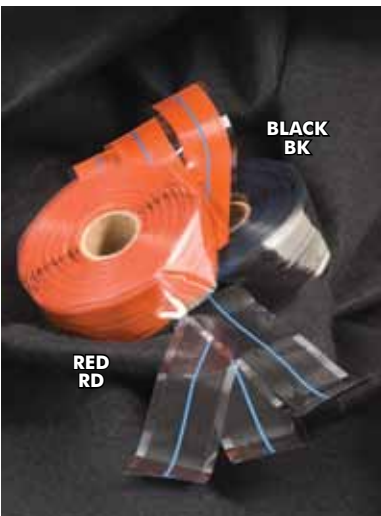

Colored guide line only on TGL (Triangular Guide Line) tapes.



Forget Your Old School Tricks!
Seal Silicone Tape Has NO STICKY GLUE!



INSULATION CLASS
May be used in many Class A & Class B applications.

CLASS*	20,000 HR LIFE TEMP.
A	221°F (105°C)
B	266°F (130°C)

*The temperature classification indicates the maximum (hot-spot) temp. at which the insulation system can be operated for normal expected service life.

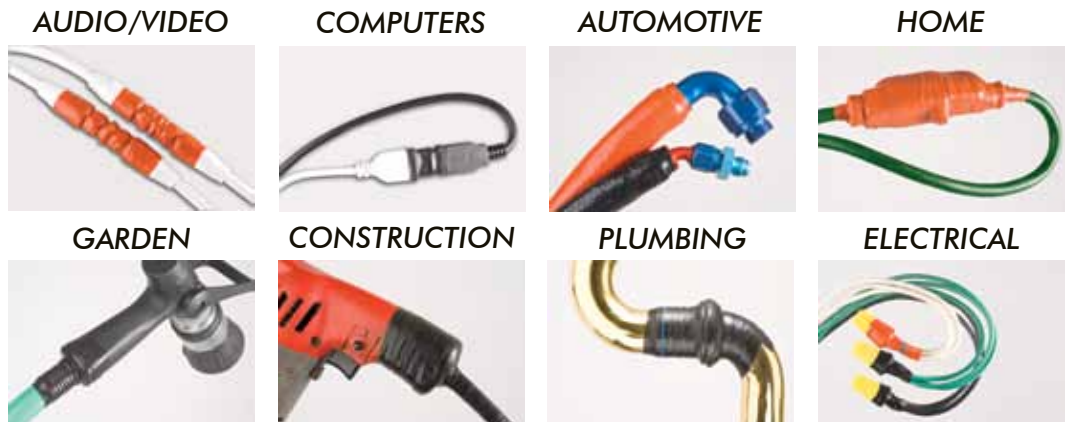

Width	Part #	Wall Thickness	Type	Qty.	Available Colors	Roll	Lbs/Roll
1"	STA1.00BK36	0.020"	Triangular	1	BK	36'	0.29
1"	STA1.00RD36	0.020"	Triangular	1	RD	36'	0.33
1"	STB1.00BK36	0.040"	Triangular	1	BK	36'	0.57
1"	SRA1.00BK36	0.020"	Rectangle	1	BK	36'	0.45
1"	SRA1.00RD36	0.020"	Rectangle	1	RD	36'	0.50
1"	SRB1.00BK36	0.040"	Rectangle	1	BK	36'	0.75

800 323-5140
www.techflex.com

Sleeving & Accessory Kits

For Do It Yourself Projects & Retail Sales

Underneath the new names and vibrant graphics, and inside the eye-catching packaging, Techflex provides the same extensive range of high quality products that our customers have always relied on. Manageable case lot minimums and flexible color assorting make Techflex braided sleeving kits ideal for small dealers and high volume outlets alike.



High Performance Products

Techflex High Performance products are engineered to provide wire and cable management, and thermal protection in automotive and marine applications. The extensive selection of High Performance products ensures a product that will fill any customization or renovation needs.

Enhance nighttime bicycling safety by installing these highly reflective F6 Reflex sleeves on your bicycle cables. Thousands of miniature retroreflective lenses reflect light back to the source from up to 675 ft. away. The wraparound design easily slips on over existing cables with no tools or disassembly required. A profitable value added service bicycle sales repair and rental shops.

F6 Reflex® Bike Kits

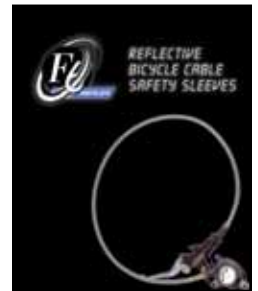

Case Mod® Computer Cable Customization Kits

After the flashing fan lights, the neon glow, the custom water-cooled case and the super-charged components, the final touch for computer case customization is "modding" the cables that connect everything. Our Case Mod Customization line provides computer enthusiasts with over 200 products to choose from, including UV reactive colors, to manage and customize the wires, cables and hoses in their supercharged custom cases.

Flexo® Scuba Hose Covers

When underwater safety is the primary concern, the FLEXO line of expandable braided sleeving adds an important and comforting level of protection and visibility. For years, commercial and recreational divers have been protecting and identifying their hoses with FLEXO expandable braided sleeving. The tough braided sleeving provides a layer of protection from abrasion, degradation and wear, and the bright colors increase visibility underwater.



Flyflex® Fly Tying Body Material

Flyflex is one of the most unusual and effective fly and lure body materials to come around in a long time. It integrates easily into time tested construction and presentation techniques, yet allows for new and exciting configurations. The flexible, expandable material is tough enough to resist repeated uses, salt water and UV damage, and provides an "al-luring" new facet to the sport.



We also manufacture Cordmate® Dockside Power Cable Sleeves, Flexo Mounting System and Small Office/Home Office Cable Management kits. For detailed information about any of these product lines, please contact an Account Representative.

800 323-5140

www.techflex.com

Display Rack

For By-The-Foot Sales and Easy Access

Display Rack - DSN0.00BK



The display rack can be installed on:



*Slot Wall



*Grid Wall



Counter



Wall

*Mounting hardware included.

Spool and product management is now simpler and more efficient than ever. Our new display/dispenser rack allows easy control of sleeving inventories and provides a controlled system of neatly dispensing directly from the spools. The rack is constructed from tough ABS plastic, with plenty of room for a wide range of products. The spools simply drop into the preformed slots and turn freely for dispensing. Full visibility and access ensures easy management of remaining inventory and simple drop-in replacement of empty spools.



The display rack holds up to 6 shop spools.

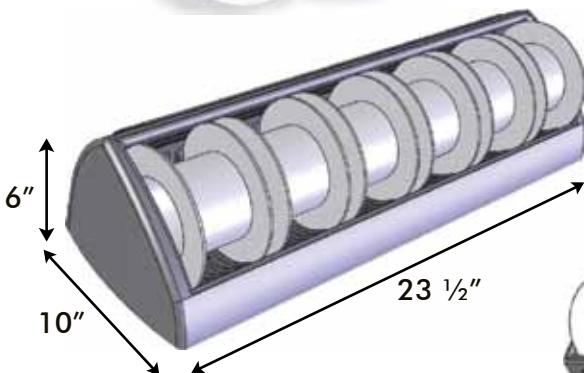

Space saving, easy access design

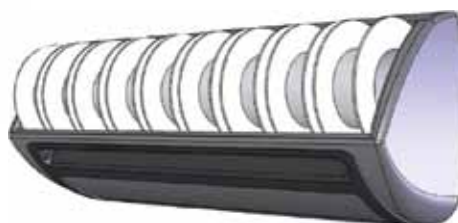

Engineered for easy and secure wall mounting

800 323-5140
www.techflex.com

Cutting To Prevent Fraying



Products displaying this icon should be cut with a hot knife, rope cutter or some other method for cutting and sealing the ends to prevent fraying during the installation and assembly process. We offer an assortment of tools to accomplish this, ranging from heavy duty, high volume devices to portable gas powered units.



Measure the sleeving to length. Keep the sleeving relaxed and don't pull it as you measure. The most accurate method is to measure the sleeving on the actual application. There will be some foreshortening of the sleeving as it expands over large bundles or connectors. Mark the cut line with a pen or marker.



When the knife is hot, slide the sleeving over the cutting blade. Practice on a piece of scrap to get a feel for the procedure. Always cut in a well ventilated area and avoid inhaling the fumes. Both the blade and the cut ends will be **HOT**. Be careful.

While the ends are still hot, use an inverted funnel (needle nose pliers or scissors also work well) to form the end into a soft flare. This will allow the sleeving to easily slide over your application and accommodate plugs or connectors without binding.



To install the sleeving over your application, just push the flared end over the ends of the wires and "walk" the sleeve down the length of the bundle from behind. Once the sleeving is in place, just run your hand over the applied sleeving to smooth it out.



Handheld Hot Knife

Perfect for individual projects or small volume production. The large knife blade heats quickly and easily cuts and seals most grades of braided sleeving. Handle can also be used as a soldering gun with the appropriate tips. 110 volt operation.

Hand Held Hot Knife - **HKH0.00BK**
Replacement Knife Blade - **RBH0.00SV**



Heavy Duty Handheld Hot Knife

German engineered, heavy duty handheld hot knife. Long life trigger switch. Heats quickly to 1,112°F/600°C. Interchangeable blades. 110 or 220 volt models available.

HD Handheld Knife 110 volt - **GK10.00GN**
HD Handheld Knife 220 volt - **GK20.00GN**

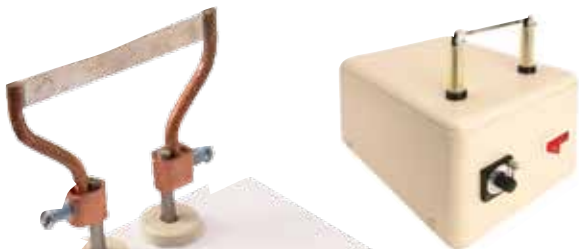

Heavy Duty Hot Knife

Thermostatically controlled electronics heat the 3" carbide blade to 1,112°F/600°C in less than ten seconds and maintain preset temperature indefinitely. Heavy duty, German engineered tool will slice through advanced chemistry polymer sleeving without dragging. Available in 110 or 220 volt models.

Heavy Duty Hot Knife 110 volt - **GK50.00BE**
Heavy Duty Hot Knife 220 volt - **GK60.00BE**

Compact Hot Knife

25mm blade heats to 1,112°F/600°C in less than 10 seconds. 6" long. Weighs under 4 lbs. Replaceable carbide steel blade. Made in Germany. Available in 110 and 220 volt models.

Compact Hot Knife 110 volt - **GK30.00BE**
Compact Hot Knife 220 volt - **GK40.00BE**



Bench Mount Hot Knife

Heavy duty components and heavy gauge 2 1/2" blade make this tool ideal for use in production environments. Lighted power switch. Heats to 1,112°F/600°C in 30 seconds. Replaceable blades. 110 volt operation.

Bench Mount Hot Knife - **HKB0.00WH**
Replacement Knife Blade - **RBB0.00SV**

Cutting & Installation Tools

Solder-It Hot Knife Kit

When AC power isn't available, this refillable butane powered torch fills the bill for cutting and sealing braided sleeving. Push-button ignition, adjustable to 932°F/500°C, up to 3 hour capacity and **BONUS** cutting blade attachment.

Butane Hot Knife Kit - **HKP0.00SV**
Replacement Blade - **RBPO.00SV**



Heavy Duty Serrated Edge Scissors

Serrated, angled shears are ideal for cutting Clean Cut, Flexo Stainless and other sleeving types. Comfortable, high impact grips and stainless steel blades ensure years of use.

Heavy Duty Serrated Edge Scissors - **SHR0.00SV**



Economy Kevlar Shears

For non-production volumes, these lightweight economical shears easily cut through Kevlar and other aramid materials. Handle color may vary.

Economy Kevlar Shears - **SHR0228-AS**



F6 Installation Tool

This simple tool makes installing long lengths of F6 sleeving a breeze. Just insert your bundle of wires into the shank of the tool and slide it along the split in the sleeving. As the tool travels along the sleeving, it deposits the wires and allows the split to close correctly.



For Installing 1/4" F6 Sleeving - **INN0.25OR**
For Installing 1/2" F6 Sleeving - **INN0.50OR**
For Installing 3/4" F6 Sleeving - **INN0.75OR**
For Installing 1" F6 Sleeving - **INN1.00OR**
For Installing 1 1/2" F6 Sleeving - **INN1.50OR**

Premium Kevlar Shears

The properties that make Kevlar so tough in use also make the material a challenge to cut to length. These special shears make short work of trimming Kevlar sleeving to the proper length.

Premium Kevlar Shears - **KVS0.00SV**



Flexo Flange

Techflex's Flexo Flange is a quick and effective way of creating permanent wiring installations attractively and affordably. Flexo Flange is used in a variety of applications where a secure, finished end is desirable. The processed ends add hundreds of pounds of strain relief. This innovation opens a whole new world of management possibilities that are production ready. For our installer solution see page 47.



FEN1.75BK3
FEN1.75BK5
FEN1.75BK7
FEN1.75BK10
FEN1.75BK12
FEN1.75BK15
FEN1.75BK20
FEN1.75BK25
FEN1.75BK30
FEN1.75BK40
FEN1.75BK50
FEN1.75BK75
FEN1.75BK100

Sleeving Installation Tool

1. Gather Sleeving on Fixture



2. Feed Wires



3. Set-Up Pulleys



4. Pull Wires & Sleeving



This completely modular system allows production level installation of braided sleeving over wire and cable bundles of virtually unlimited length. The system is simple to set up and interchangeable components accommodate diameters up to 2". For more information about this product contact your Account Representative.

Custom Services & Products

From simple cutting and bundling services to custom product design and production, we are dedicated to providing our customers with a complete range of product options. Many of our braided products can be produced in special colors or construction types. Labor saving services such as product rounding reduce installation time (and costs) for end users and fabricators. Just ask us... we can probably do it for you.



Cut to Length/Coiling/Bundling

An inch or a hundred feet; a dozen pieces or ten million, our precision cutting equipment and skilled operators will cut any stock or custom product to your specs and tolerances. Cut pieces can then be coiled or wrapped in counted bundles, bagged, labeled and shipped.



Ultrasonic Cleaning

To accommodate strictly specified clean room uses such as aerospace and biomed, we can remove any oils and residue accumulated on the material during manufacturing. After cleaning, we will either bag or respool material on new, clean spools, using oil-free respooling equipment and individually wrap each spool to minimize any recontamination of the material during transit.



Heat Treating/ Rounding

As easy as it is to work with braided sleeving, it can be made even easier to install. Heat treating and rounding the

spooled sleeving opens it up and "sets" it so that it remains open along the entire length. The sleeving retains all of it's original properties, and installation is even easier for long runs of wire or cable. Ask an Account Representative for details.



Splice Free Spools

Some splices are normal during the braiding process. Usually, not more than one or two splices will be on any given spool. Ordering splice-free spools guarantees the maximum continuous yield on your spools.

Overbraiding

Customer supplied material can be overbraided with virtually any of our products. As an integral part of the production process, overbraiding provides the ultimate custom look and feel to any application. Our high-speed equipment and quick turnaround ensure minimum waste and virtually eliminate delay further down the manufacturing chain.



Custom Construction

By altering the structure of the actual braid, the entire visual effect of the sleeving can be changed without affecting any of the material's properties. Note the difference between the standard 3/3 braid on the left and the custom 1/1 braid on the right. Our team will work with you to engineer the perfect product for your application.



Custom Colors/Blends/Sizes

Many of our current stock solid and multiple colors started out as custom products specified by customers. We can color match virtually any Pantone® spot color in almost any combination of braid patterns and color combinations. Additionally, we can braid these custom colors into custom diameters to meet unique customer specifications.



Assembly & Fabrication

We can assist our sleeving customers with everything from custom product development and design assistance to final assembly services in our production facility. We are equipped and staffed to provide a wide range of fabrication services and custom assembly solutions. Our commitment to complete customer satisfaction ensures a smooth production stream and high quality products and services.

Custom Fabrication

When it comes to extending the limit of uses for expandable sleeving, nobody can push the envelope of possibility further than Techflex. That's why Nike approached us with their plans for an unusual treatment on their newest line of high-end basketball shoes. The design called for start to finish customization, as well as an aggressive production/shipping schedule that would ensure that their product launch was on time and that they could fill the thousands of anticipated orders.

We are equipped and experienced in many custom fabrication services, including:

- **Product Engineering Assistance**

Our design & engineering staff works closely with each client to adjust our production specs to accommodate their design and production requirements.

- **Custom Product Design**

New braid structures and custom colors can be engineered to produce the necessary visual effect while fulfilling requirements for strength and flexibility.

- **Precision Flattening/Rounding**

The tubular material can be permanently flattened or rounded to tight tolerances to be further processed.

- **Ultrasonic Shaping and Welding**

Custom tooling for our entire in-house line by ultrasonic equipment ensures precision cutting to complex shapes within tight specifications.

- **Custom/Private Label Packaging & Spooling**

Techflex has been packaging braided sleeving products for other companies since our inception nearly 40 years ago.

We've done everything from simple plastic bags with header cards to blister packs to revisions of our existing clamshell templates to fully customized packaging solutions. Additionally, we can create custom spool solutions to fit your unique storage and branding requirements.



A dedication to service and a full range of fabrication capabilities brought Nike on board for the tongue and tab detail on this line of Air Jordan shoes.



- **Scientific Quality Control Systems**

Automated visual inspection system to 100% ensure parts consistency and calibrated physical and chemical testing can be performed as required for custom product applications.

- **Custom Printing Services**

We have in-house pad and thermal printing facilities to imprint up to two color logos on heatshrink tubing or braided sleeving.

- **Sleeving Installation Services**

Our production facility is equipped to receive bulk customer products, professionally install and terminate any type of sleeving and promptly package and ship finished product for distribution.

- **Prototyping**

Our production team will work with your design/engineering staff to provide samples of various sleeving/termination solutions during your initial product design stages.

- **JIT (Just in Time) Shipping**

We can accommodate your incremental shipping schedule ensuring sufficient quantities of approved fabricated parts delivered to downstream production facilities without delay. Contact your Account Manager for domestic, international and interplanetary shipping options.



**PRODUCT
COMPARISON**

GENERAL PURPOSE



Grade	PTN	PTM	PTO	PTT	CCP	F6N	FWN	GWN	HWN	SDN
Page Number	4-5	5	6	6	7	8-9	10	11	12	13
PHYSICAL PROPERTIES										
Monofilament Diameter ASIMD204	.010	.010	.010	.010	.008	.008-.015	.010	.010	.015	.020
Flammability Rating*	UL94	UL94	UL94	UL94	UL94	UL94	—	—	UL94	—
Recommended Cutting	Hot Knife	Hot Knife	Hot Knife	Hot Knife	Scissor/HK	Hot Knife	Hot Knife	Hot Knife	Hot Knife	Hot Knife
Colors	27	4	7	1	2	4	4	1	3	1
Wall Thickness	.025	.025	.025	.025	.024	.024-.038	.025	.025	.038	.05
Tensile Strength (Yarn) ASIMD2256 Lbs	7.5	7.5	7.5	7.5	6	6-10	7.5	7.5	10	19
Abrasion Resistance	Med	Med	Low	Med	Med	Med	Med	Med	High	High
Specific Gravity ASIMD792	1.38	1.38	1.38	1.38	1.38	1.38	1.38	1.38	1.38	1.14
Moisture Absorption % ASIMD570	.1-.2	.1-.2	.1-.2	.1-.2	.1-.2	.1-.2	.1-.2	.1-.2	.1-.2	2.5
Hard Vacuum Data ASIME585 at 105 tar										
TML	.19	.19	.19	.19	.19	.19	.19	.19	.19	1.10
CVCM	.00	.00	.00	.00	.00	.00	.00	.00	.00	.01
WVR	.16	.16	.16	.16	.16	.16	.16	.16	.16	.69
Smoke D-Max ASIME662	56	56	56	56	56	56	56	56	56	
Outgassing	Med	Med	Med	Med	Med	Med	Med	Med	Med	High
Oxygen Index ASIMD2863	21	21	21	21	21	21	21	21	21	22
OPERATING TEMPERATURES										
Minimum Continuous	-94°F/-70°C	-94°F/-70°C	-94°F/-70°C	-94°F/-70°C	-94°F/-70°C	-94°F/-70°C	-103°F/-75°C	-94°F/-70°C	-94°F/-70°C	-49°F/-45°C
Maximum Continuous MI423063	257°F/125°C	257°F/125°C	257°F/125°C	257°F/125°C	257°F/125°C	257°F/125°C	257°F/125°C	257°F/125°C	257°F/125°C	302°F/150°C
Melt ASIMD2117	482°F/250°C	482°F/250°C	482°F/250°C	482°F/250°C	482°F/250°C	482°F/250°C	482°F/250°C	482°F/250°C	482°F/250°C	493°F/256°C
CHEMICAL RESISTANCE 1=No Effect 2=Little Effect 3=Affected 4=More Affected 5=Severly Affected										
Aromatic Solvents	2	2	2	2	2	2	2	2	2	1
Aliphatic Solvents	1	1	1	1	1	1	1	1	1	1
Chlorinated Solvents	3	3	3	3	3	3	3	3	3	1
Weak Bases	1	1	1	1	1	1	1	1	1	1
Salts	1	1	1	1	1	1	1	1	1	1
Strong Bases	2	2	2	2	2	2	2	2	2	2
Salt Water GS1926	1	1	1	1	1	1	1	1	1	1
Hydraulic Fluid MLH6606	1	1	1	1	1	1	1	1	1	1
Lube Oil MLL7808	1	1	1	1	1	1	1	1	1	1
De-Icing Fluid MLA8243	1	1	1	1	1	1	1	1	1	1
Strong Acids	3	3	3	3	3	3	3	3	3	5
Strong Oxidants	2	2	2	2	2	2	2	2	2	5
Esters/Keytones	1	1	1	1	1	1	1	1	1	1
UV Light	1	1	1	1	1	1	1	1	1	2
Petroleum	1	1	1	1	1	1	1	1	1	3
Fungus ASIMG21	1	1	1	1	1	1	1	1	1	2
Halogen Free	Yes	Yes	Yes	Yes	Yes	Yes	Yes	Yes	Yes	Yes
RoHS	Yes	Yes	Yes	Yes	Yes	Yes	Yes	Yes	Yes	Yes
SVHC	None	None	None	None	None	None	None	None	None	None
UL/CSA	Yes	Yes	Yes	Yes	Yes	Yes	Yes	Yes	Yes	No

*UL94 V-0 RAW MATERIAL

HEAVY DUTY

METAL/SHIELDING

ADVANCED ENGINEERING



NHN	DWN	DFN	DPN	MBN	SSN	SSL	FSN	CNN	CCF	FRN	L6N	F6F
14	15	16	17	18	19	19	20	21	22	23	24	25
FLAT FILAMENT .020	NA	NA	NA	.005-.010	.010-.016	.005-.010	.010	.011	.008	.010	NA	.008-.015
—	—	—	—	Non Flammable	Non Flammable	Non Flammable	Non Flammable	—	VW-1	VW-1	—	VW-1
Hot Knife	Scissor	Scissor	Scissor	Shears	Shears	Shears	Shears	Hot Knife	Scissor/HK	Hot Knife	Scissor	Scissor/HK
1	1	1	1	1	1	1	1	1	2	4	2	1
.05	.026	.045	.08	.013-.025	.025-.04	.013-.025	.025	.028	.024	.025	.046	.024-.038
19									4	5		4-6.5
Extremely High	Extremely High	High	Extremely High	Med	High	High	Low	Med	Med	Med	NA	High
1.12	1.13	1.14	1.14	NA	NA	NA	NA	1.13	1.38	1.38	NA	1.38
2.5	2.7	2.7	2.7	NA	NA	NA	NA	2.5	.1-2	.1-2	NA	.1-2
1.10	1.10	1.10	1.10		.00	.00		.19	.19	.19		.19
.01	.01	.01	.01		.00	.00		.04	.04	.04		.04
.69	.69	.69	.69		.00	.00		.06	.06	.06		.06
									275	275		275
High	High	High	High		Very Low	Very Low			Med	Med		Med
22	22	22	22						31	31		31
-76°F/-60°C	-60°F/-51°C	-49°F/-45°C	-49°F/-45°C	—	—	—	-40°F/-40°C	-49°F/-45°C	-94°F/-70°C	-94°F/-70°C	-94°F/-70°C	-94°F/-70°C
302°F/150°C	200°F/93°C	248°F/120°C	248°F/120°C	—	—	—	302°F/150°C	302°F/150°C	257°F/125°C	257°F/125°C	257°F/125°C	257°F/125°C
509°F/265°C	410°F/210°C	410°F/210°C	410°F/210°C	449°F/232°C	2,650°F/1,454°C	2,650°F/1,454°C	449°F/232°C	482°F/250°C	482°F/250°C	482°F/250°C	482°F/250°C	446°F/230°C
1	1	1	1	1	1	1	2	1	2	2	2	2
1	1	1	1	1	1	1	1	1	1	1	1	1
1	1	1	1	1	1	1	3	1	3	3	2	3
1	1	1	1	1	1	1	1	1	1	1	1	1
1	1	1	1	1	2	2	1	1	1	1	1	1
2	2	2	2	2	2	2	2	2	2	2	3	2
1	1	1	1	1	2	2	1	1	1	1	1	1
1	1	1	1	1	1	1	1	1	1	1	1	1
1	1	1	1	1	1	1	1	1	1	1	1	1
5	4	5	5	5	2	2	3	4	3	3	3	3
5	4	5	5	5	2	2	2	4	2	2	2	2
1	1	1	1	1	1	1	1	1	2	2	1	1
1	1	2	2	2	1	1	1	2	1	1	1	1
2	2	3	3	2	1	1	1	3	1	1	1	1
2	1	2	2	2	1	1	1	2	1	1	1	1
No	Yes	Yes	Yes	Yes	Yes	Yes		Yes	Yes	Yes	Yes	Yes
Yes	Yes	Yes	Yes	Yes	Yes	Yes	Yes	Yes	Yes	Yes	Yes	Yes
									None	None	None	None
No	No	No	No	No	No	No	Yes	No	Yes	Yes	No	Yes

© 2011 Techflex, Inc. - Any unauthorized reproduction, in whole or part, in any medium whatsoever, without the express written permission of Techflex, Inc. is strictly forbidden.

Techflex product names and logos are registered trademarks of Techflex, Inc., unless otherwise attributed. The contents and illustrations contained herein are believed to be reliable. Techflex makes no warranties as to their accuracy or completeness and disclaims any liability in connection with their use. Techflex's only obligations are those in standard terms of sale for these products and Techflex will not be liable for any consequential or other damages arising due to misuse of these products or typographical errors or omissions. Users should make their own evaluation to determine the suitability of these products for their unique and specific applications.

**PRODUCT
COMPARISON**

ADVANCED ENGINEERING



Grade	FWF	F9T	HTN	TFN	RYN	KVN	VEN	FGN	FGL	FHN
Page Number	26	27	28	29	30	31	31	32	33	34

PHYSICAL PROPERTIES

Monofilament Diameter ASIMD204	.010	.009	.011	.016	.008	NA	NA	NA	NA	NA
Flammability Rating*	VW-1	FAR 25	FAR 25, VW-1	FAR 25	FAR 25, UL94 V-0	—	Self Extinguishing	VW-1	VW-1	VW-1
Recommended Cutting	Hot Knife	Hot Knife	Hot Knife	Hot Wire/Knife	Hot Knife	Kevlar Shears	Kevlar Shears	Scissor	Scissor	Scissor
Colors	1	1	2	1	2	1	1	2	2	1
Wall Thickness	.025	.023	.028	.04	.024	.02	.025	.031-.061	.006-.016	.010-.024
Tensile Strength (Yarn) ASIMD256 Lbs	5	4.5	4.3	2.1	6.1	39	20			
Abrasion Resistance	Med	Med	Med	Very High	Med	Med	High	High	Med	Med
Specific Gravity ASIMD792	1.38	1.38	1.68	2.15	1.37	1.44	1.4	1.0-1.8	1.0-1.8	1.0-1.8
Moisture Absorption % ASIMD670	.1-2	.1-2	.02	<.01	.02		<.005	.01	.01	.01

Hard Vacuum Data ASIME586 at 105 tar

TML	.19	.19	.18	.00	.08	3.13	.21	.02	.02	.01
CVCM	.04	.04	.02	.00	.00	.19	.00	.01	.01	.00
WVR	.06	.06	0	0	.04	1.76	.00	.00	.00	.00
Smoke D-Max ASIME662	275		94							
Outgassing	Med	Med	Low	Very Low	Low	High	Med	Low	Low	Low
Oxygen Index ASIMD2863	31	31	64	>95	40	29	>30			

OPERATING TEMPERATURES

Minimum Continuous	-94°F/-70°C	-94°F/-70°C	-103°F/-75°C	-94°F/-70°C	-94°F/-70°C	-274°F/-170°C	—	-94°F/-70°C	-94°F/-70°C	-94°F/-70°C
Maximum Continuous MI423053	257°F/125°C	257°F/125°C	302°F/150°C	550°F/280°C	392°F/200°C	320°F/160°C	—	1,202°F/650°C	1,202°F/650°C	1,202°F/650°C
Melt ASIMD2117	482°F/250°C	482°F/250°C	482°F/250°C	590°F/310°C	545°F/285°C	NA	625°F/330°C	2,048°F/1,120°C	2,048°F/1,120°C	2,048°F/1,120°C

CHEMICAL RESISTANCE 1=No Effect 2=Little Effect 3=Affected 4=More Affected 5=Severely Affected

Aromatic Solvents	2	2	1	1	1	2		1	1	1
Aliphatic Solvents	1	1	1	1	1	2		1	1	1
Chlorinated Solvents	3	3	1	1	1	2	1	1	1	1
Weak Bases	1	1	1	1	1	1		1	1	1
Salts	1	1	1	1	1	1		1	1	1
Strong Bases	2	2	1	1	1	2		1	1	1
Salt Water GS1926	1	1	1	1	1	1	1	1	1	1
Hydraulic Fluid MLH5606	1	1	1	1	1	1	1	1	1	1
Lube Oil MLH7808	1	1	1	1	1	1	1	1	1	1
De-Icing Fluid MLH8243	1	1	1	1	1	1		1	1	1
Strong Acids	3	3	1	1	1	2		2	2	2
Strong Oxidants	2	2	1	1	1	2		2	2	2
Esters/Keytones	2	2	2	2	1	1		1	1	1
UV Light	1	1	1	1	1	4		2	2	2
Petroleum		1	1	1	1	1	1	1	1	1
Fungus ASIMG21	1	1	1	1	1	2		1	1	1
Halogen Free	Yes	Yes	No	No	Yes	Yes		Yes	Yes	Yes
RoHS	Yes	Yes	Yes	Yes	Yes			Yes	Yes	Yes
SVHC	None	None						None	None	None
UL/CSA	Yes	Yes	Yes	No	No	No	No	Yes	Yes	Yes

*UL94 V-0 RAW MATERIAL

EXTREME TEMPERATURE PRODUCTS



FHH	See Pg. 35	HFN	HSN	VWN	SLN	T6F	See Pg. 40-41	NXN	WVN	FIN	FIA
34	35	36	36	37	38	39	40-41	42	43	44	45
NA	NA	NA	NA	NA	NA	NA	NA	NA	NA	NA	NA
VW-1	VW-1	Non Flammable	Non Flammable	Non Flammable	Non Flammable	Non Flammable	Non Flammable	Self Extinguishing	Non Flammable	Non Flammable	Non Flammable
Scissor	NA	Scissor	Scissor	Scissor	Scissor	Scissor	Scissor	Scissor/Shears	Scissor/Shears	Scissor	Scissor
1	4	2	1	1	1	1	1	2	1	2	2
.025-.035	.085	.0625-.125	.0625-.125		.06	.042	See Pg. 40-41	.016	.04	.072	.115
								8			
Med	High	NA	NA	NA	Medium	NA	NA	Low	High	Extremely High	Extremely High
1.0-1.8	1.0-1.8	2.6	2.2					1.38	NA	NA	NA
.01	.01							4			
.01	.02							3.94			
.00	.01							.18			
.00	.00							2.91			
Low	Low										
								28			
-94°F/-70°C	-94°F/-70°C	-70°F/-57°C	—	—	—	-76°F/-60°C	-76°F/-60°C	-76°F/-60°C	-40°F/-40°C	-65°F/-54°C	-65°F/-54°C
1,202°F/650°C	1,202°F/650°C	1,200°F/649°C	2,000°F/1,093°C	1,200°F/649°C	1,800°F/982°C	392°F/200°C	491°F/255°C	428°F/220°C	400°F/204°C	500°F/260°C	500°F/260°C
2,048°F/1,120°C	2,048°F/1,120°C	2,048°F/1,120°C	3,000°F/1,649°C	2,400°F/1,316°C	3,000°F/1,649°C	2,048°F/1,120°C	2,048°F/1,120°C	662°F/350°C	NA	2,048°F/1,120°C	2,048°F/1,120°C
1	1	1	1	1	1	1	1	1	1	1	1
1	1	1	1	1	1	1	1	1	1	1	1
1	1	1	1	1	1	1	1	1	1	1	1
1	1	1	1	1	1	1	1	1	1	1	1
1	1	1	1	1	1	1	1	1	1	1	1
1	1	1	1	1	1	1	1	1	1	1	1
1	1	1	1	1	1	1	1	1	1	1	1
1	1	1	1	1	1	1	1	1	1	1	1
1	1	1	1	1	1	1	1	1	1	1	1
1	1	1	1	1	1	1	1	1	1	1	1
2	2	2	2	2	2	2	2	2	2	2	2
2	2	2	2	2	2	2	2	2	2	2	2
1	1	1	1	1	1	1	1	1	1	1	1
2	2	2	2	2	2	1	1	2	1	1	1
1	1	1	1	1	1	1	1	1	1	1	1
1	1	1	1	1	1	1	1	1	1	1	1
Yes	Yes	Yes	Yes			Yes	Yes	Yes		Yes	Yes
Yes	Yes					Yes	Yes	Yes		Yes	Yes
None	None										
Yes	Yes	No	No	No	No	No	No	No	No	No	No

© 2011 Techflex, Inc. - Any unauthorized reproduction, in whole or part, in any medium whatsoever, without the express written permission of Techflex, Inc. is strictly forbidden. Techflex product names and logos are registered trademarks of Techflex, Inc., unless otherwise attributed. The contents and illustrations contained herein are believed to be reliable. Techflex makes no warranties as to their accuracy or completeness and disclaims any liability in connection with their use. Techflex's only obligations are those in standard terms of sale for these products and Techflex will not be liable for any consequential or other damages arising due to misuse of these products or typographical errors or omissions. Users should make their own evaluation to determine the suitability of these products for their unique and specific applications.

**PRODUCT
COMPARISON**

SPECIALTY PRODUCTS



Grade	SKN	DRN	NSN	NYN	NMN	MYN/MYE	CHN
Page Number	46	48	49	50	51	52	53
PHYSICAL PROPERTIES							
Monofilament Diameter ASIMD204	NA	NA	.028	.012	NA	.010	.010
Flammability Rating*	—	—	—	—	—	—	—
Recommended Cutting	Scissor	Scissor	Hot Knife	Hot Knife	Scissor	Hot Knife	Hot Knife
Colors	1 Reversible	1	3	1	1	3	1
Wall Thickness	.048	.012	.07	.03	.03-.06	.025	.025
Tensile Strength (Yarn) ASIMD256 Lbs				10.5			
Abrasion Resistance	High	Extremely High	Med	High	Extremely High	Very Low	Med
Specific Gravity ASIMD792	NA	1.13	1.38	1.14	1.14	1.3	1.3
Moisture Absorption % ASIMD570	NA	2.7	.1-.2	2.5	2.5	.1-.2	
Hard Vacuum Data ASIME595 at 105 tar							
TML				1.10	1.10	.19	.19
CVCM				.01	.01	.00	.00
WVR				.69	.69	.16	.16
Smoke D-Max ASIME662							
Outgassing				High	High	Med	Med
Oxygen Index ASIMD2863				22	22	21	21
OPERATING TEMPERATURES							
Minimum Continuous	—	-60°F/-51°C	-40°F/-40°C	-49°F/-45°C	-49°F/-45°C	-94°F/-70°C	-94°F/-70°C
Maximum Continuous MI423063	—	200°F/93°C	175°F/79°C	302°F/150°C	248°F/120°C	257°F/125°C	257°F/125°C
Melt ASIMD2117	NA	410°F/374°C	260°F/126°C	493°F/256°C	428°F/220°C	482°F/250°C	482°F/250°C
CHEMICAL RESISTANCE 1=No Effect 2=Little Effect 3=Affected 4=More Affected 5=Severely Affected							
Aromatic Solvents	1	1	2	1	1	2	2
Aliphatic Solvents	1	1	1	1	1	1	1
Chlorinated Solvents	1	1	3	1	1	3	3
Weak Bases	1	1	1	1	1	1	1
Salts	1	1	1	1	1	1	1
Strong Bases	2	2	2	2	2	3	3
Salt Water GS1926	1	1	1	1	1	1	1
Hydraulic Fluid MLH4606	1	1	1	1	1	1	1
Lube Oil MLL7808	1	1	1	1	1	1	1
De-Icing Fluid MLA8243	1	1	1	1	1	1	1
Strong Acids	4	3	3	5	5	3	3
Strong Oxidants	4	4	2	5	5	2	2
Esters/Keytones	1	1	1	1	2	1	1
UV Light	1	1	1	2	2	1	1
Petroleum	2	2	1	3	2	1	1
Fungus ASIMG21	1	1	1	2	3	1	1
Halogen Free		Yes	Yes	Yes	Yes	Yes	Yes
RoHS		Yes	Yes	Yes	Yes	Yes	Yes
SVHC						None	None
UL/CSA	No	No	No	No	No	No	No

*UL94 V-0 RAW MATERIAL

SPECIALTY PRODUCTS

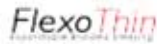

CXN	FFN	FTN	CAL/CAN/CAH	RFN	F6R	NRN	F6Q
53	54	54	55	56	56	57	57
.005	.006	.002-.003	NA	.010	.008-.015	.010	.008-.015
—	UL94	—	Non Flammable	—	—	UL94	UL94
Hot Knife	Hot Knife	Hot Knife	Scissor	Hot Knife	Hot Knife	Scissor /HK	Scissor /HK
2	1	1	1	2	1	1	1
.013	.015	.005-.008	.013-.030	.026	.024-.025	.025	.04
	4.5					7.5	7.5
Med	Low	Very Low	Med	Low	Low	Med	Med
1.3	1.38	1.14	1.75-1.85	1.38	1.38	1.38	1.38
.1-.2	.1-.2	2.5		.1-.2	.1-.2	.1-.2	.1-.2
.19	.19	1.10				.19	.19
.00	.00	.01				.00	.00
.14	.16	.69				.16	.16
Med	Med	High				Med	Med
21	21	22				21	21
-94°F/-70°C	-94°F/-70°C	-49°F/-45°C	—	-22°F/-30°C	-22°F/-30°C	-94°F/-70°C	-94°F/-70°C
302°F/150°C	257°F/125°C	248°F/120°C	—	257°F/125°C	257°F/125°C	257°F/125°C	257°F/125°C
500°F/260°C	482°F/250°C	428°F/220°C	NA	446°F/230°C	446°F/230°C	446°F/230°C	466°F/230°C
2	2	1		2	2	2	2
1	1	1		1	1	1	1
3	3	1		3	3	3	3
1	1	1		1	1	1	1
1	1	1		1	1	1	1
3	2	2		2	2	2	2
1	1	1		1	1	1	1
1	1	1		1	1	1	1
1	1	1		1	1	1	1
1	1	1		1	1	1	1
3	3	5		3	3	3	3
2	2	5		2	2	2	2
1	1	1	1	1	1	1	1
1	1	2	2	1	1	1	1
1	1	2		1	1	1	1
1	1	3		1	1	1	1
Yes	Yes	Yes		Yes	Yes	Yes	Yes
Yes	Yes	Yes		Yes	Yes	Yes	Yes
None	None					None	None
No	No	No	No	No	No	No	No

© 2011 Techflex, Inc. - Any unauthorized reproduction, in whole or part, in any medium whatsoever, without the express written permission of Techflex, Inc. is strictly forbidden.

Techflex product names and logos are registered trademarks of Techflex, Inc., unless otherwise attributed. The contents and illustrations contained herein are believed to be reliable. Techflex makes no warranties as to their accuracy or completeness and disclaims any liability in connection with their use. Techflex's only obligations are those in standard terms of sale for these products and Techflex will not be liable for any consequential or other damages arising due to misuse of these products or typographical errors or omissions. Users should make their own evaluation to determine the suitability of these products for their unique and specific applications.



We are committed to providing the most advanced products, the widest selections, the most knowledgeable customer service and the best value to our customers.



CALL

1-800-323-5140

1-973-300-9242 in NJ

1-970-352-2355 in CO

FAX

1-973-300-9409 in NJ

1-970-352-3828 in CO

MAIL

TECHFLEX Inc.

29 Brookfield Drive
Sparta, NJ 07871

TECHFLEX West Inc.

300 East 16th Street #306
Greeley, CO 80631

WEBSITE

www.techflex.com



29 Brookfield Drive
Sparta, NJ 07871

U.S. Postage
PAID
Permit No. 88
Sparta, NJ 07871